



anwis

} roman blinds



R009

PG A

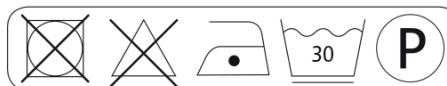
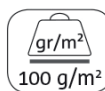
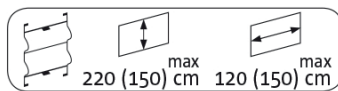
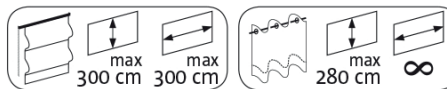

R009

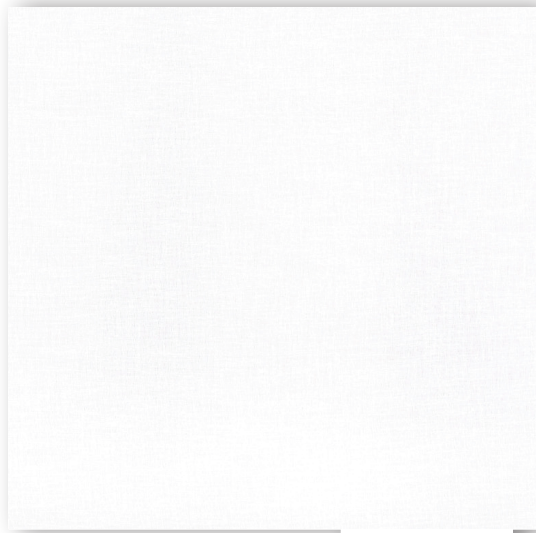

R200

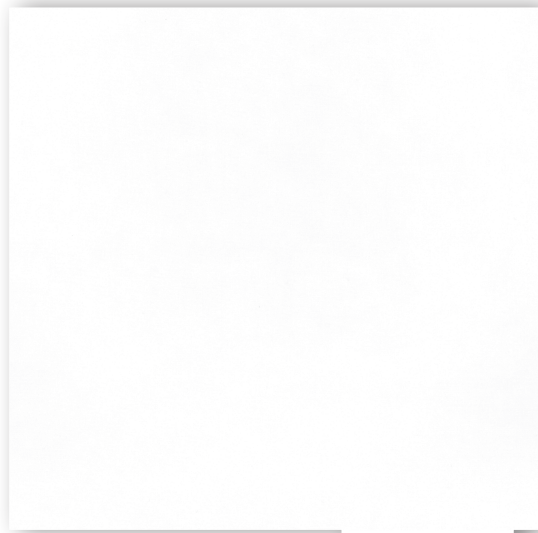

R420

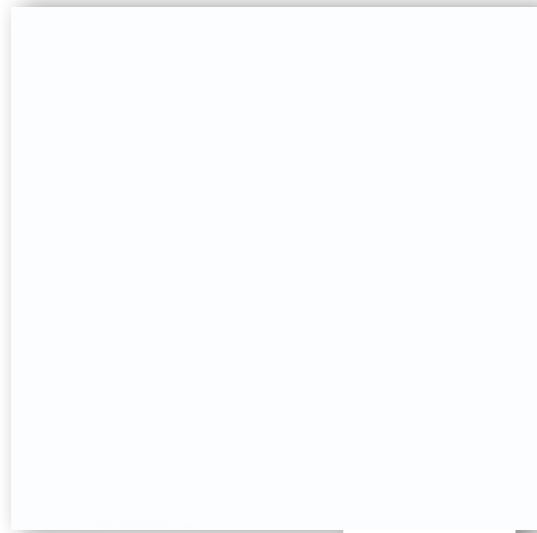

R612

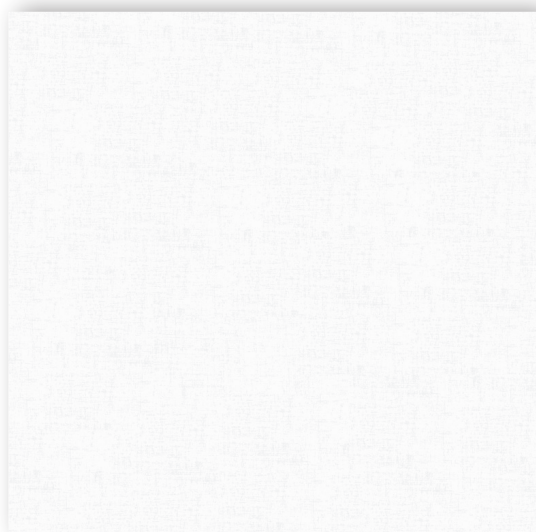

R020

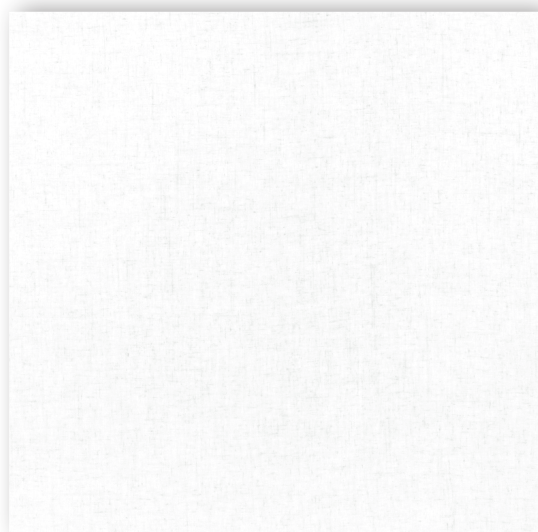

R230

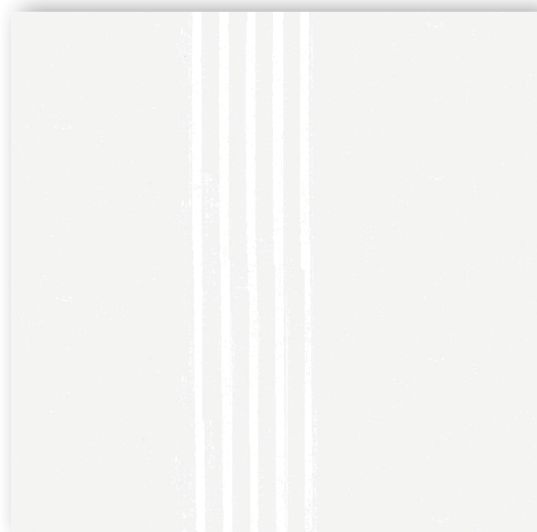

R214

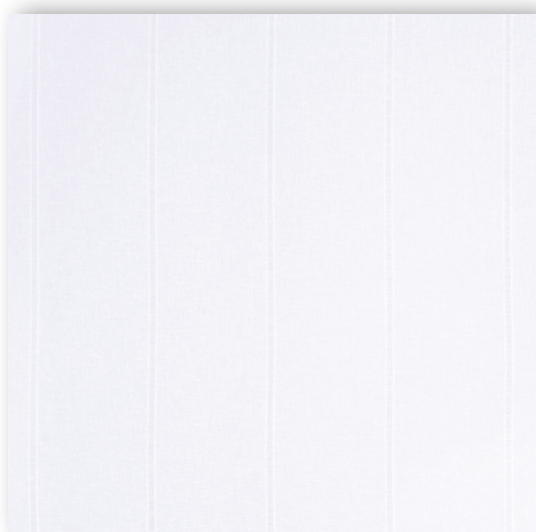

R001

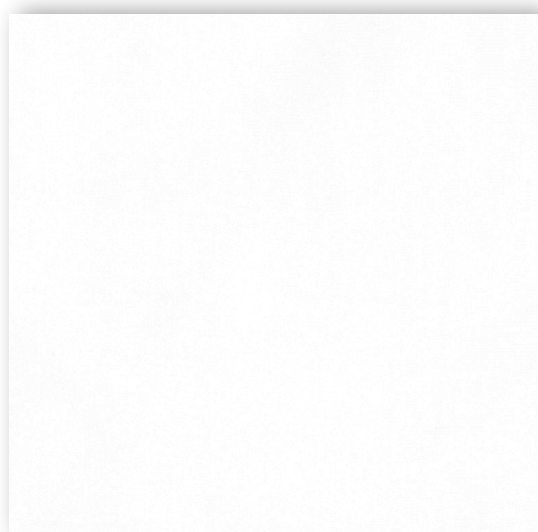

R831

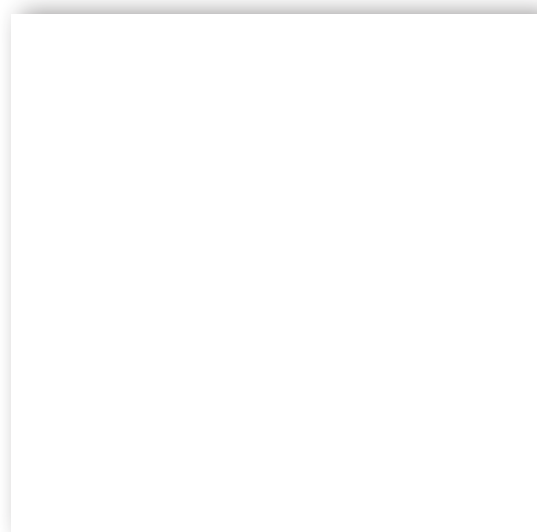

R216

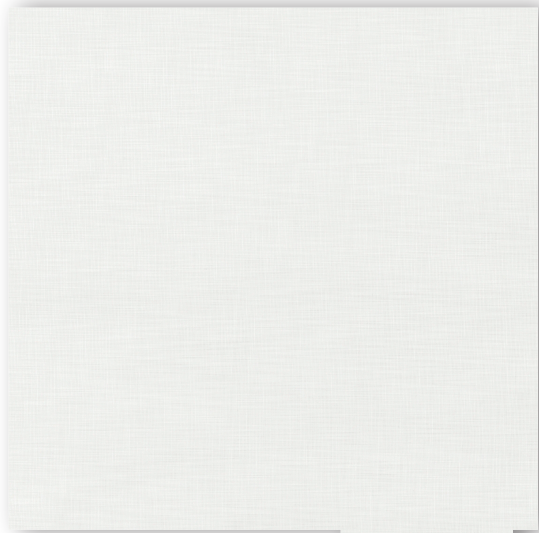

R800



R600



Blackout

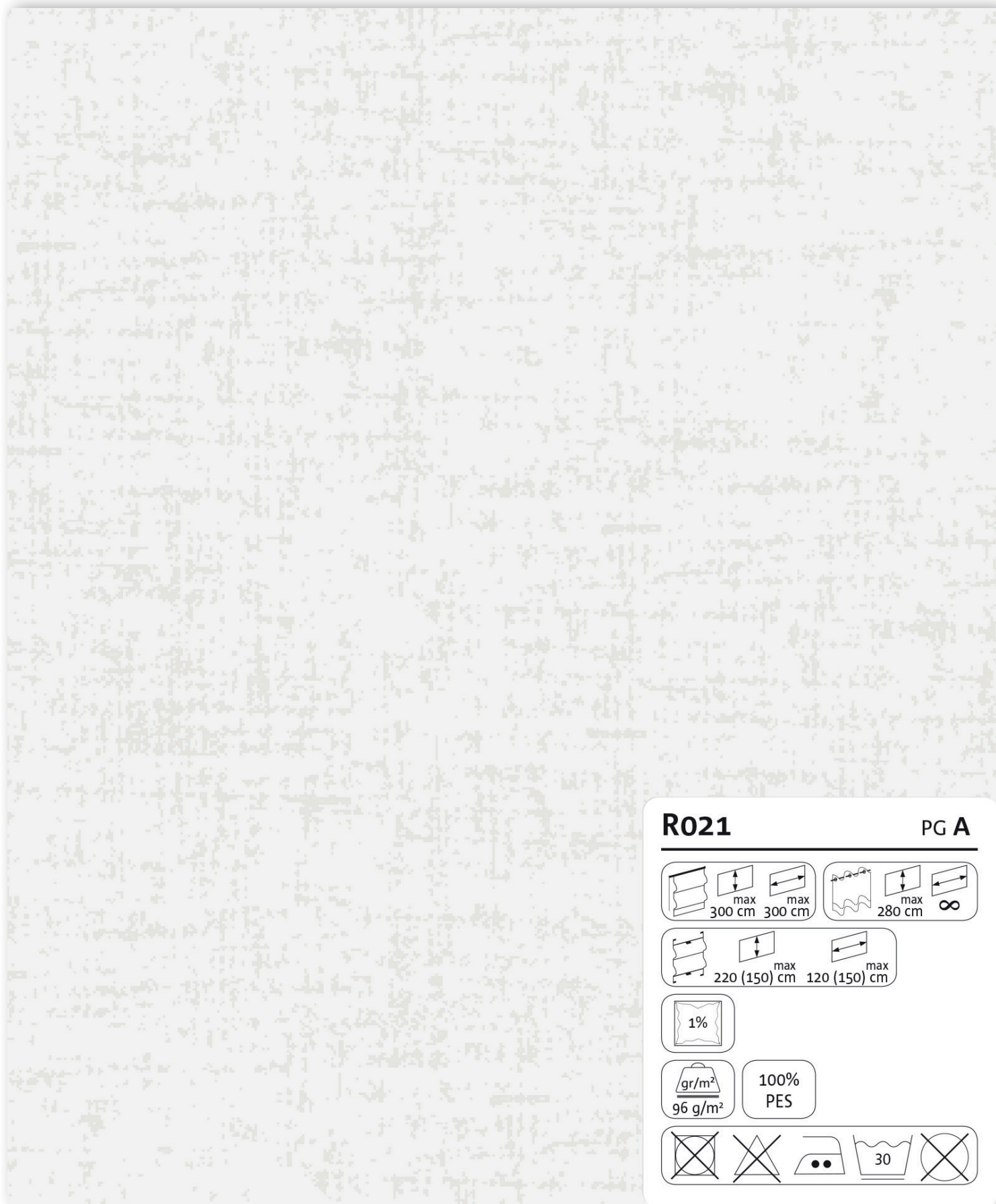

R021

PG A

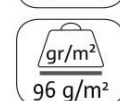
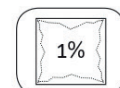
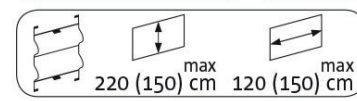
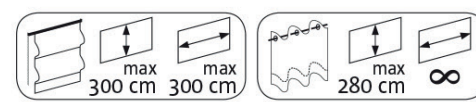

R021

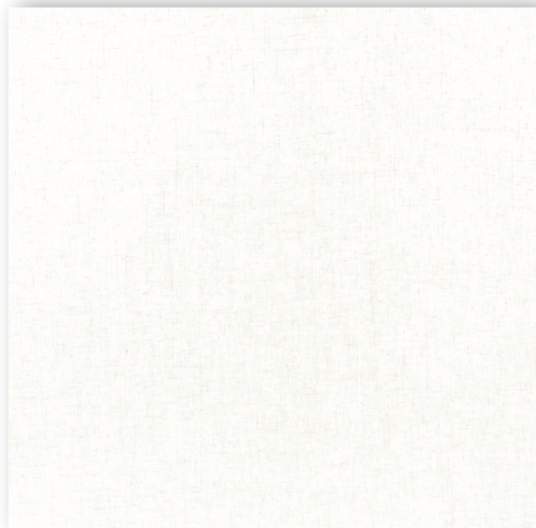

R231

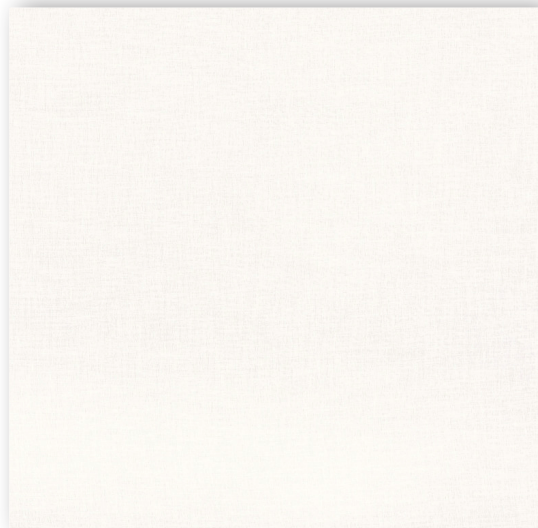

R201

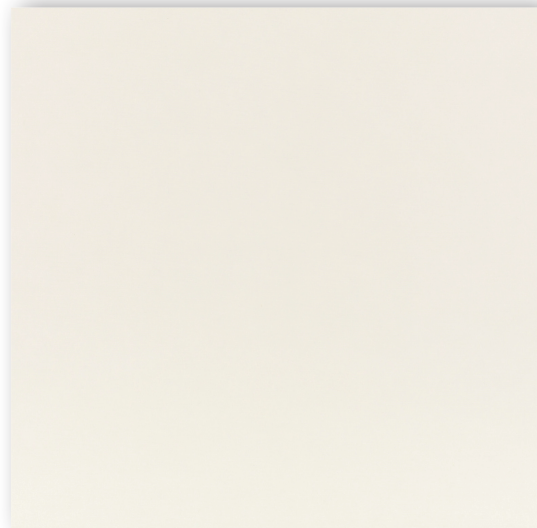

R421

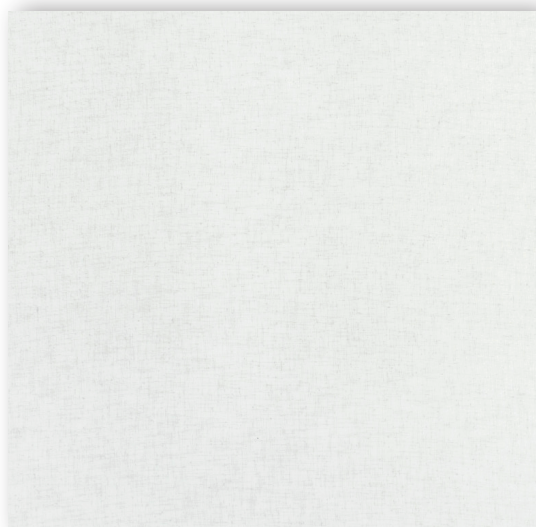

R014



R002

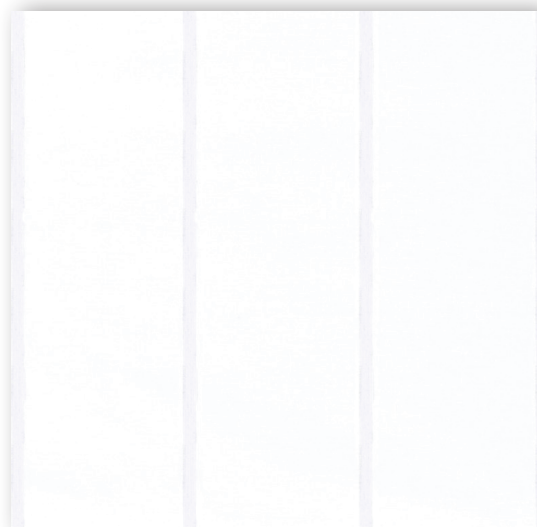

R006

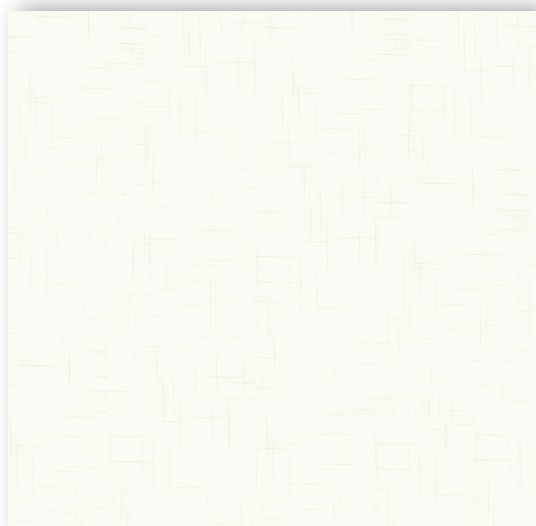

R011

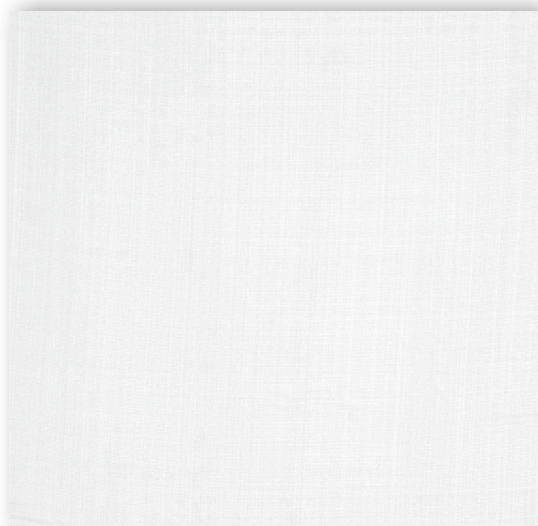

R217

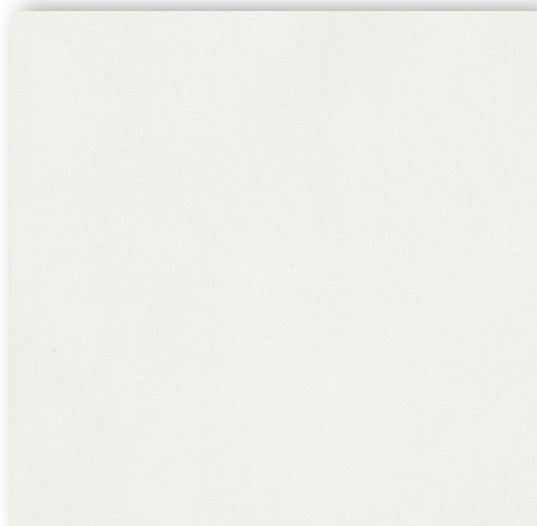

R832

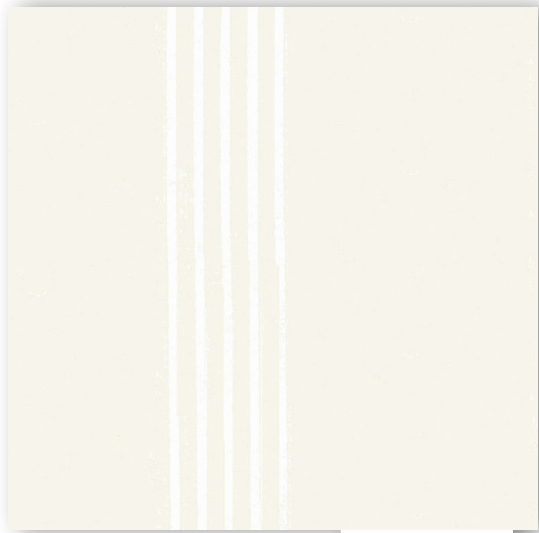

R215

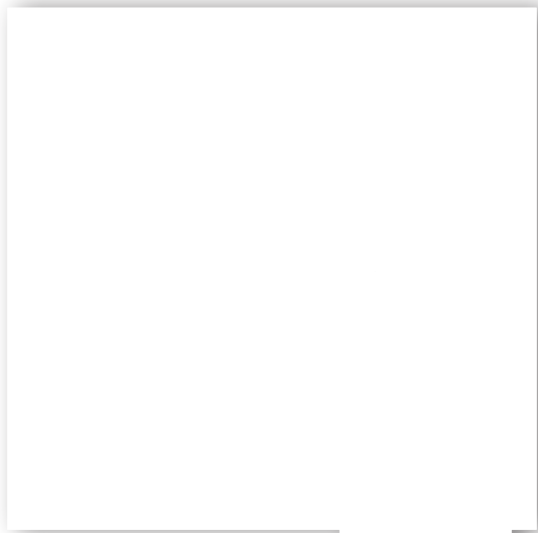

R613

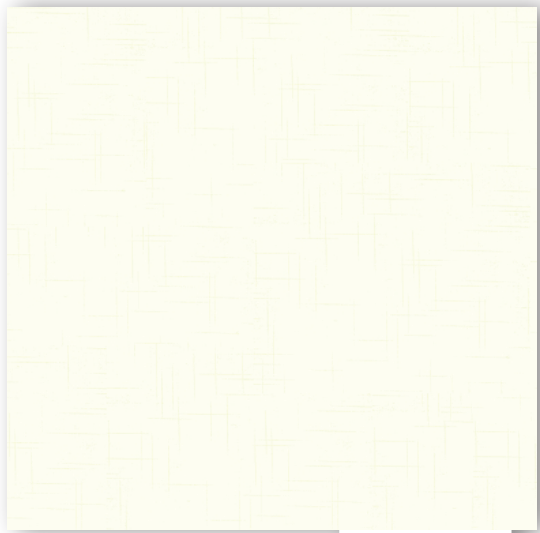

R010

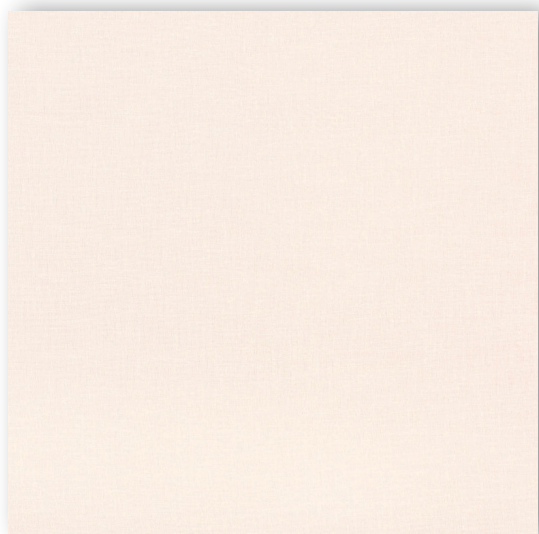

R202

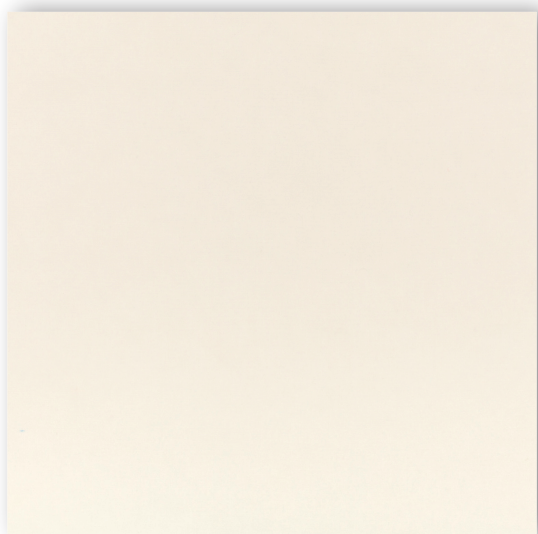

R422

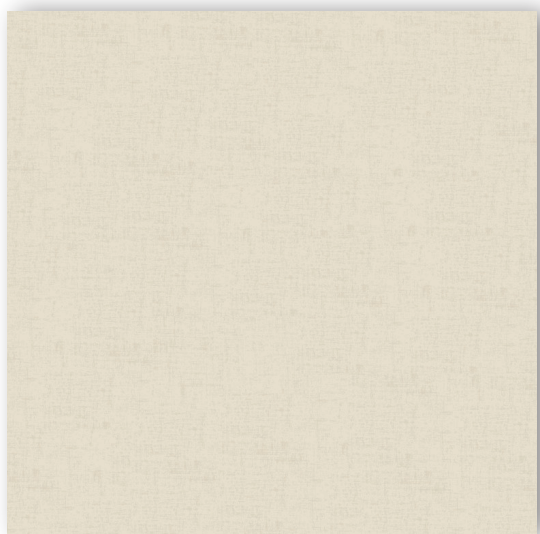

R022



R801

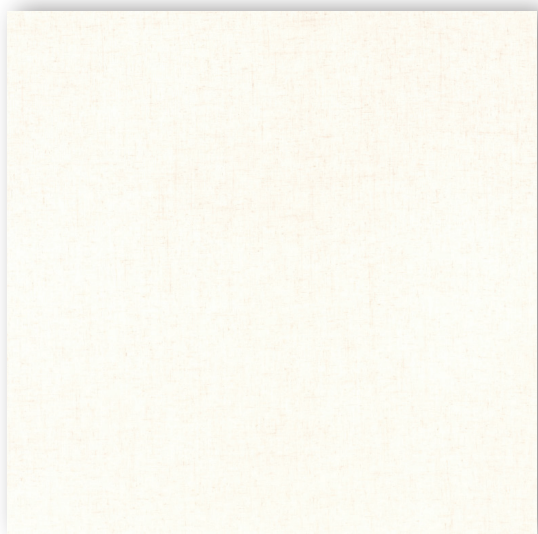

R233

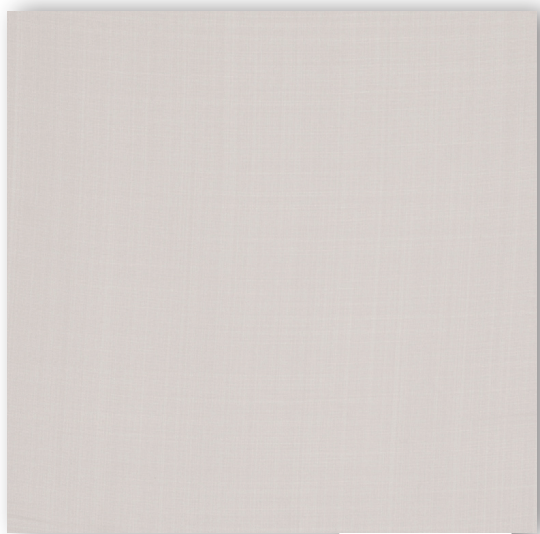

R218



Blackout

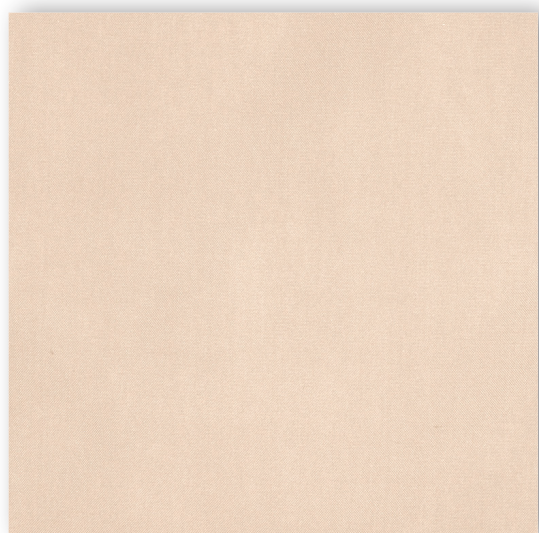

R833



R410



R614

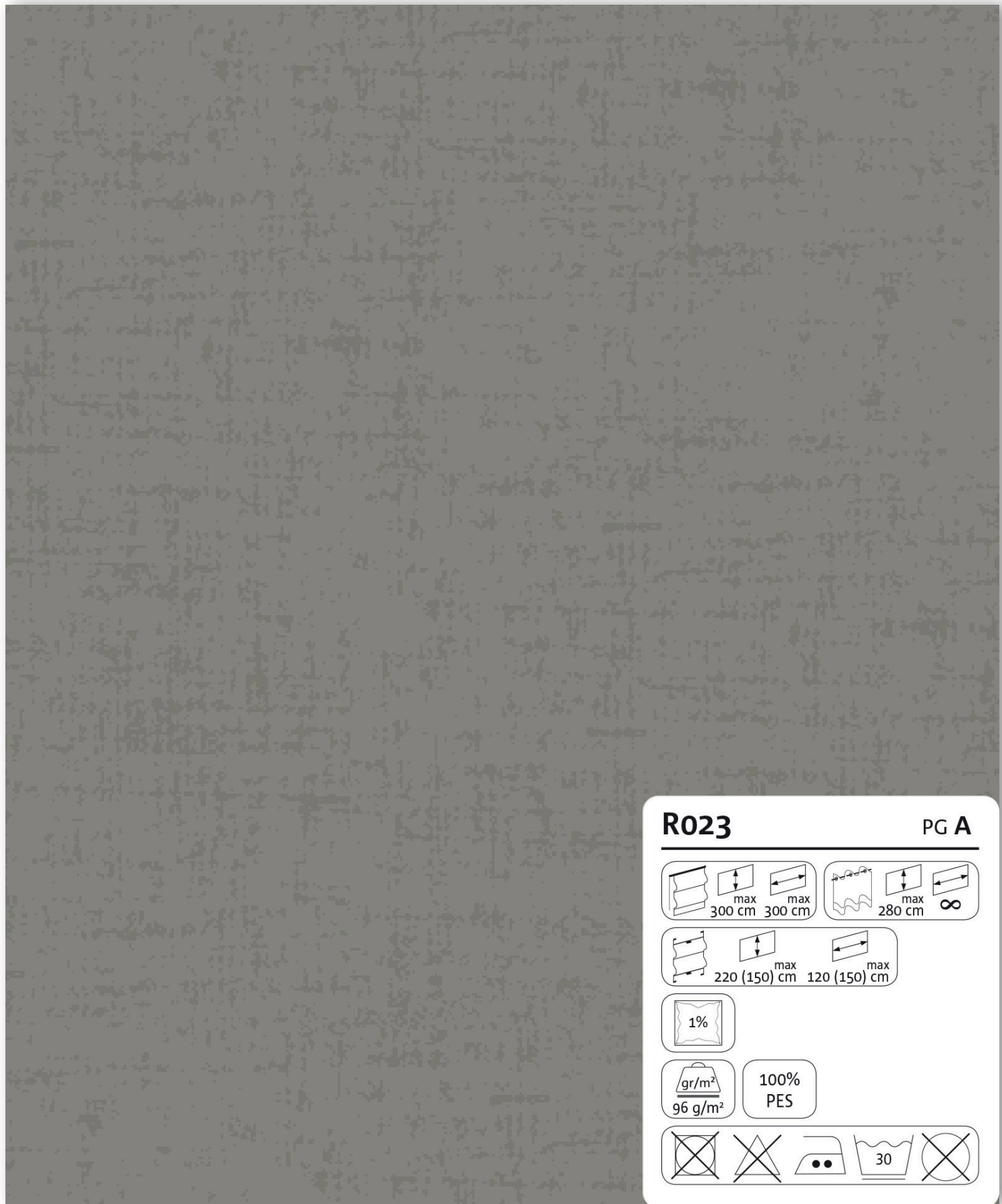

R023

PG A

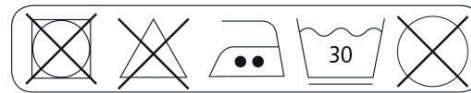
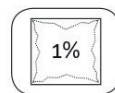
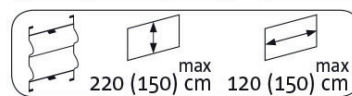
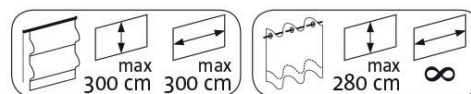

R203

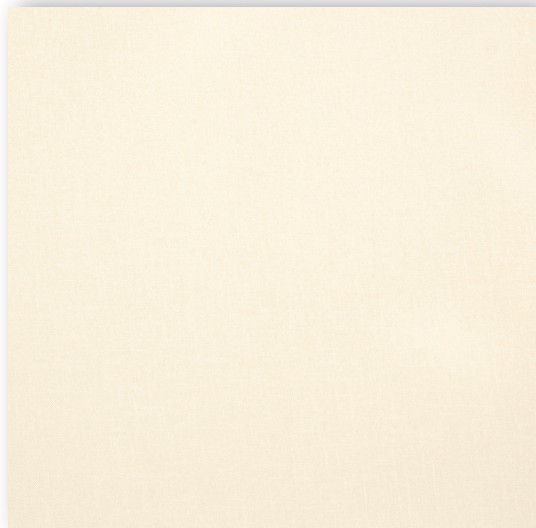

R616



R241

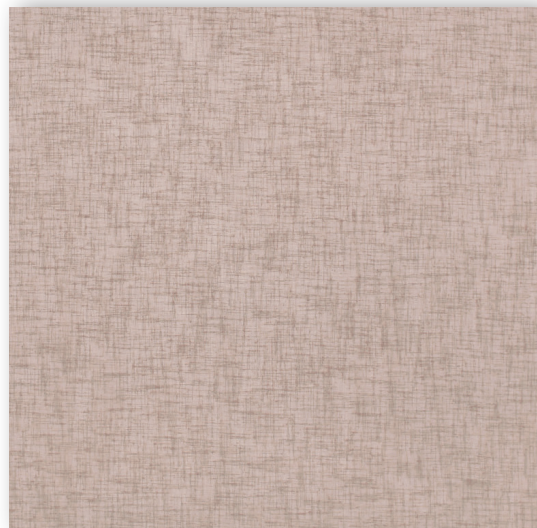

R209



R234



R400

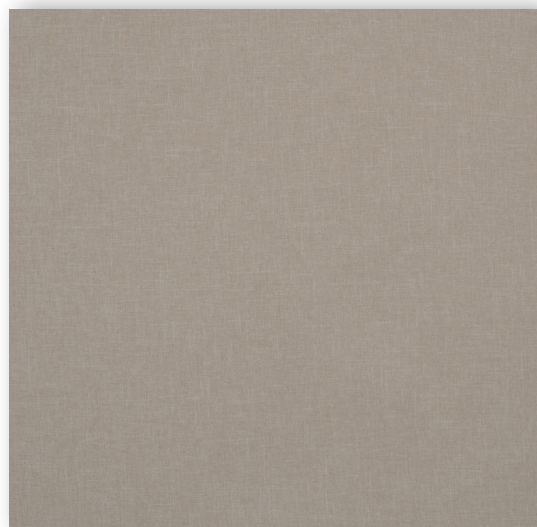

R617



R208

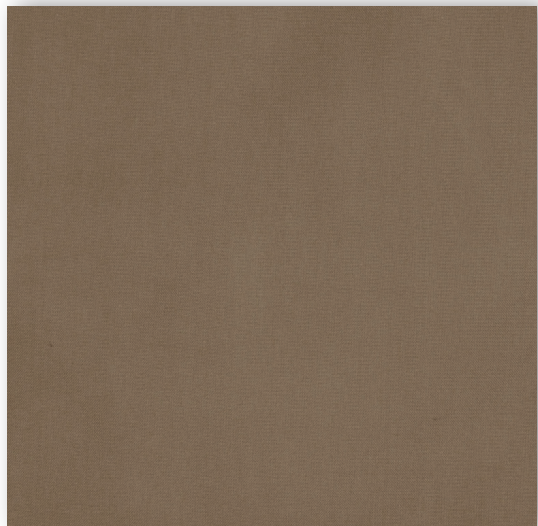

R838

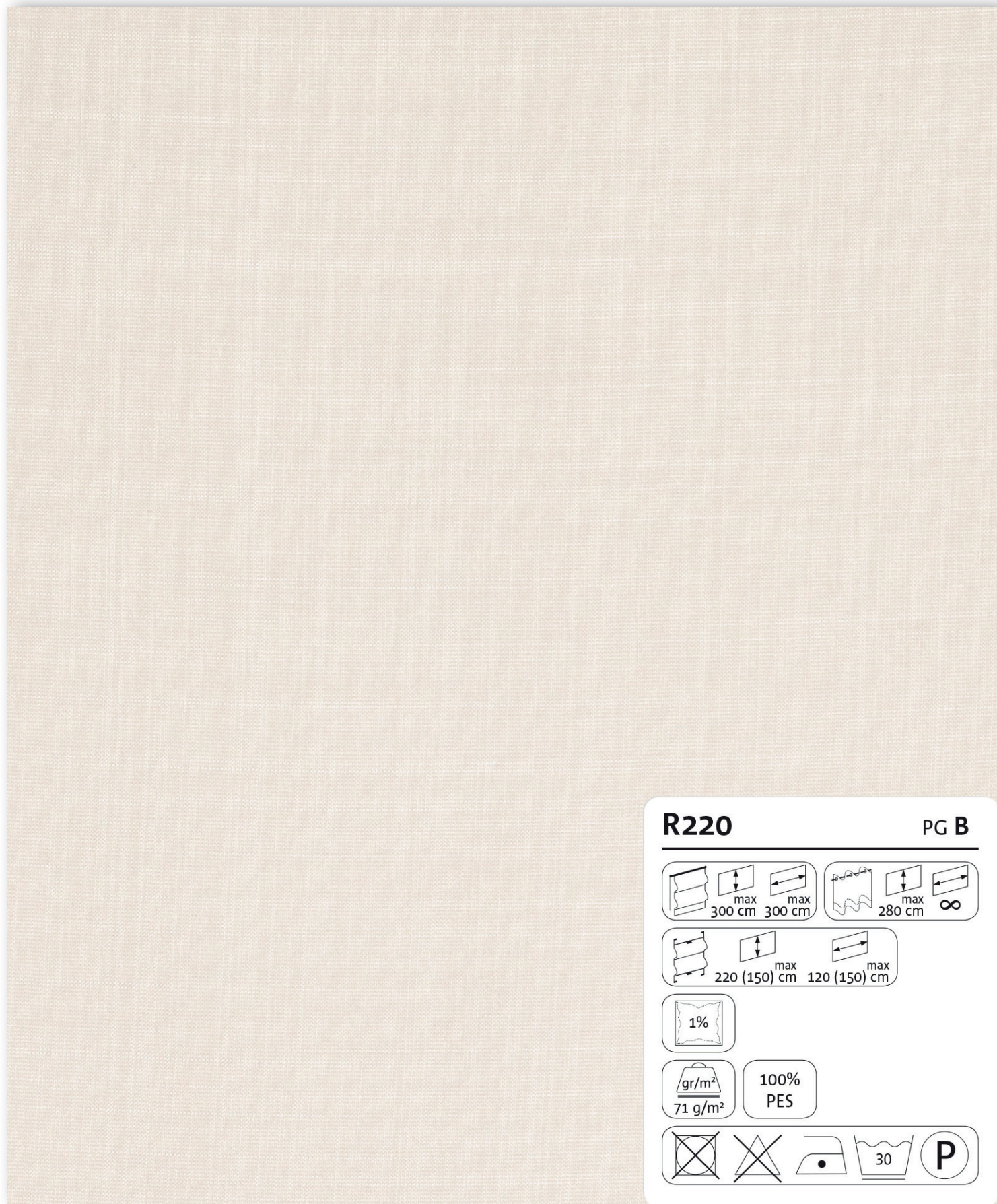

R220

PG B

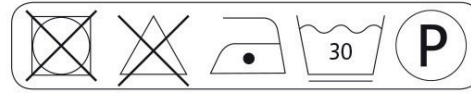
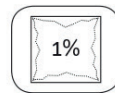
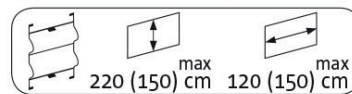
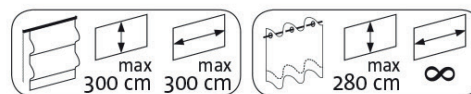

R220

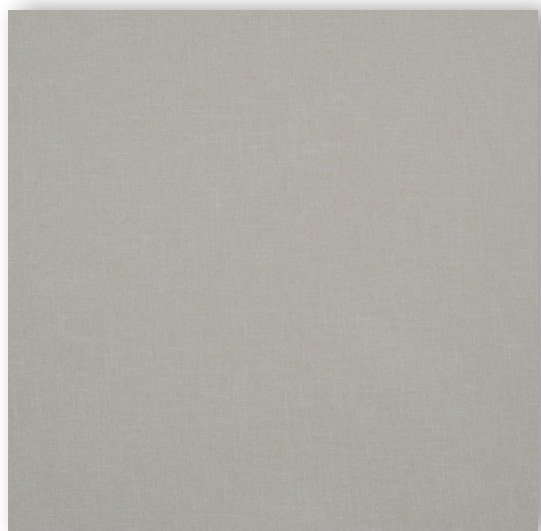

R615



R007

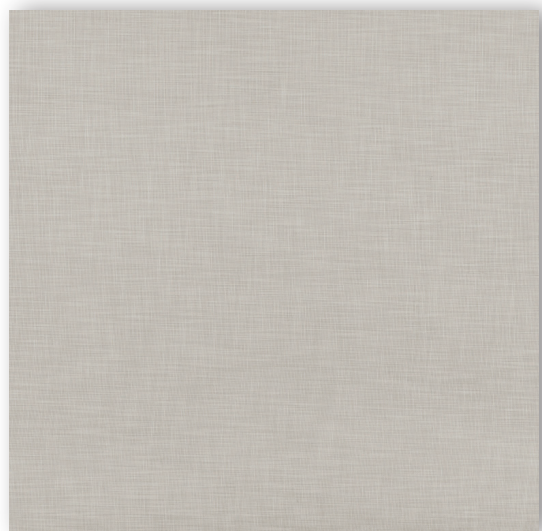

R814



R204

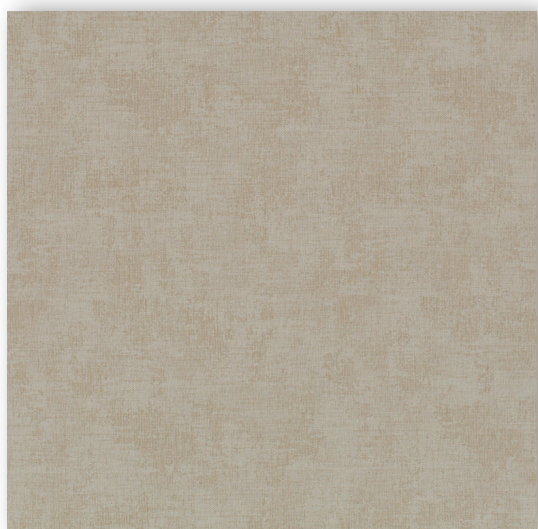

R825

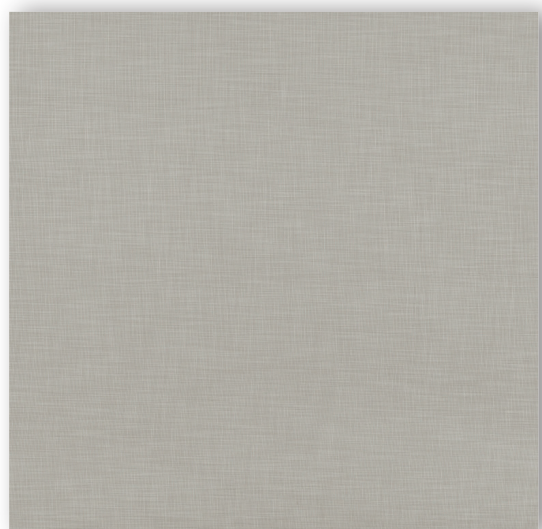

R817



R601



R826

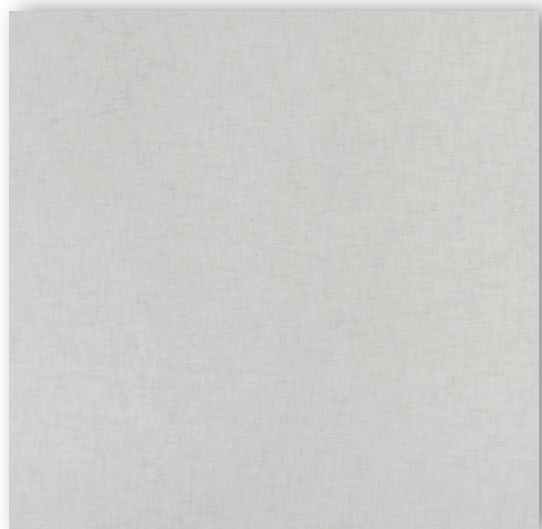

R015



R003

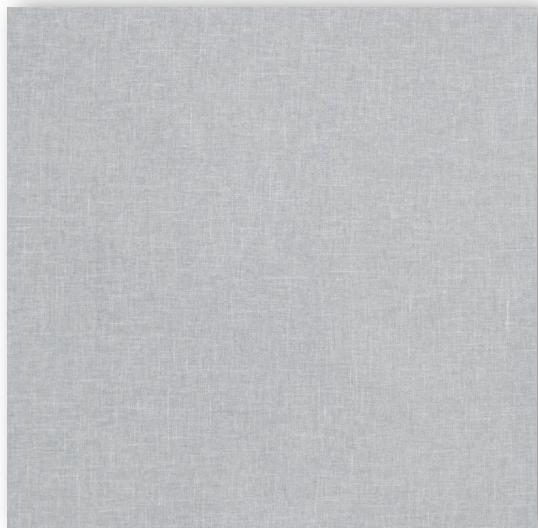

R640

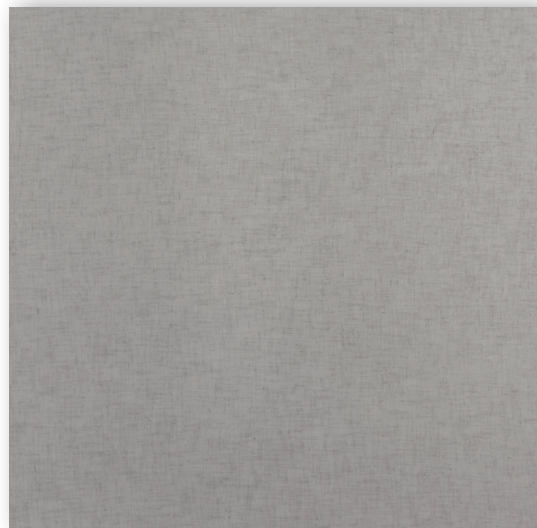

R017

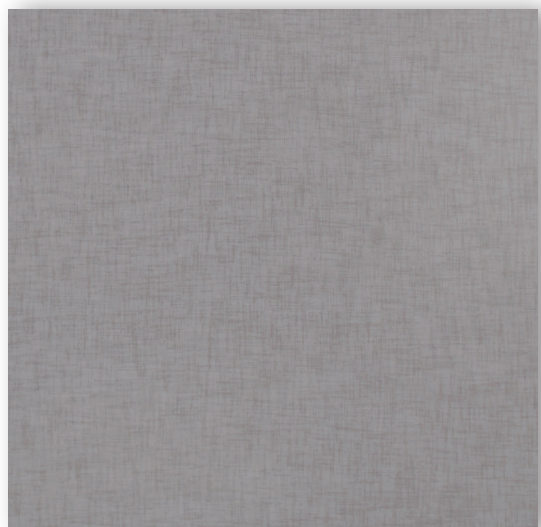

R210

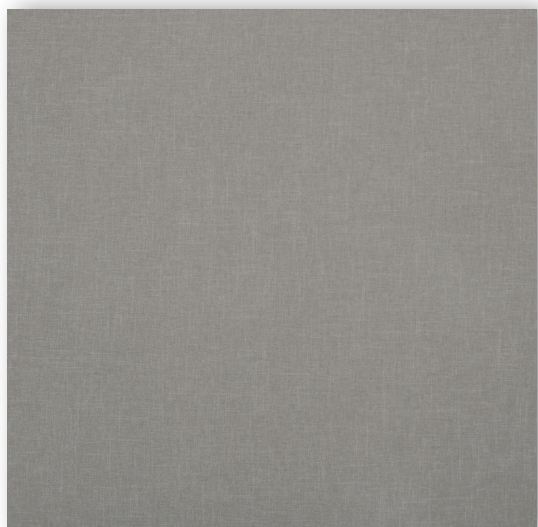

R641



R827

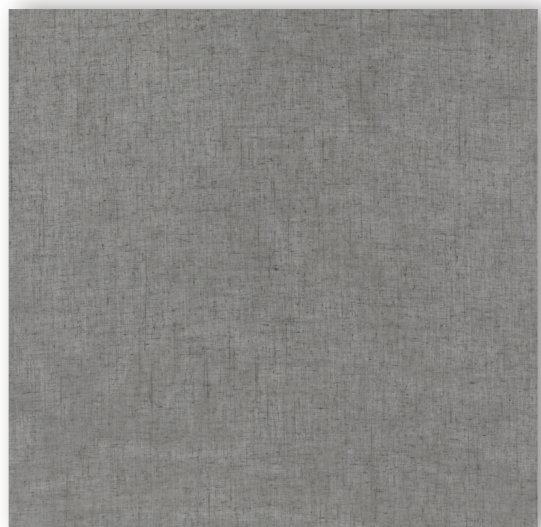

R239



R424

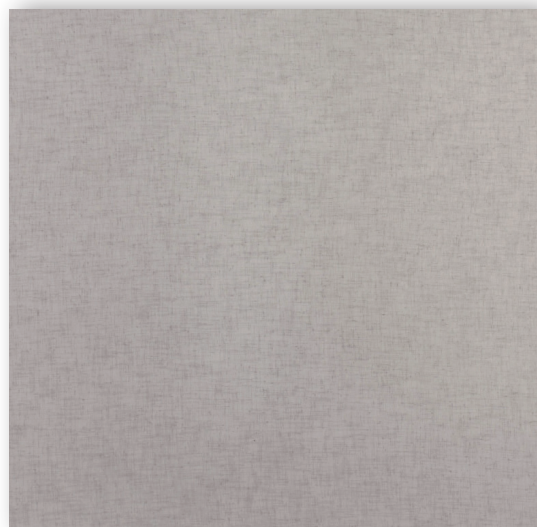

R016



Blackout



R004

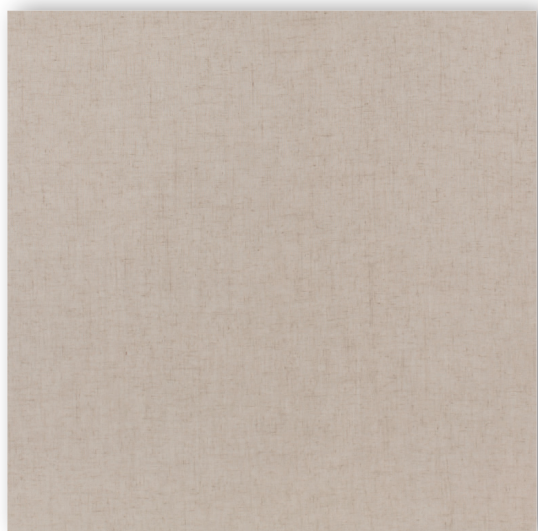

R235



R207



R237

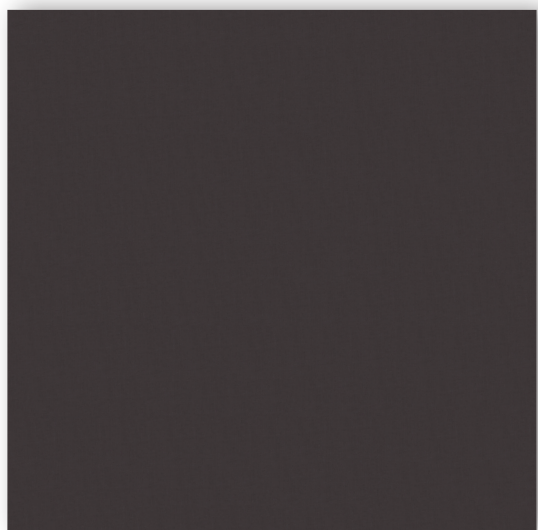

R423

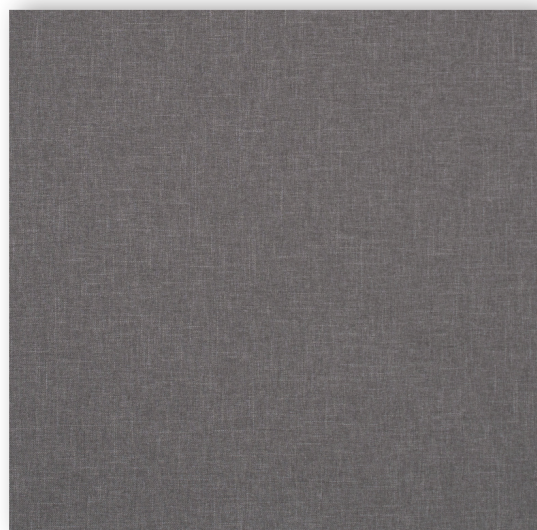

R637

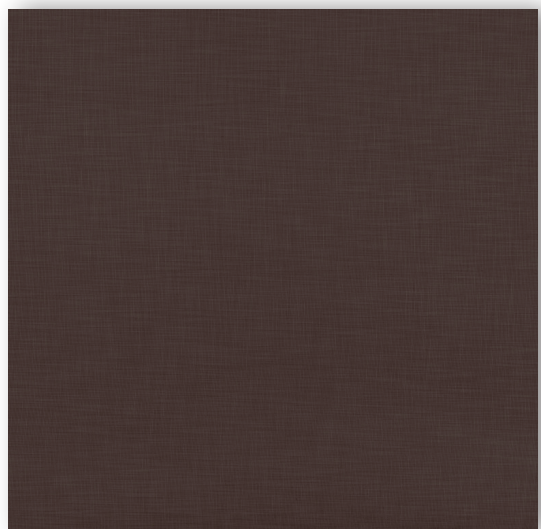

R815

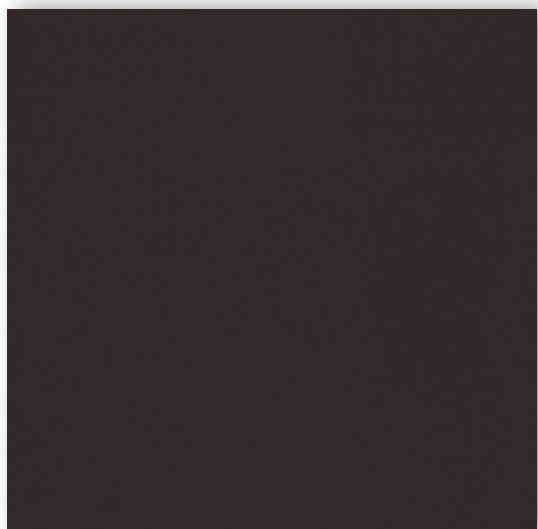

R414

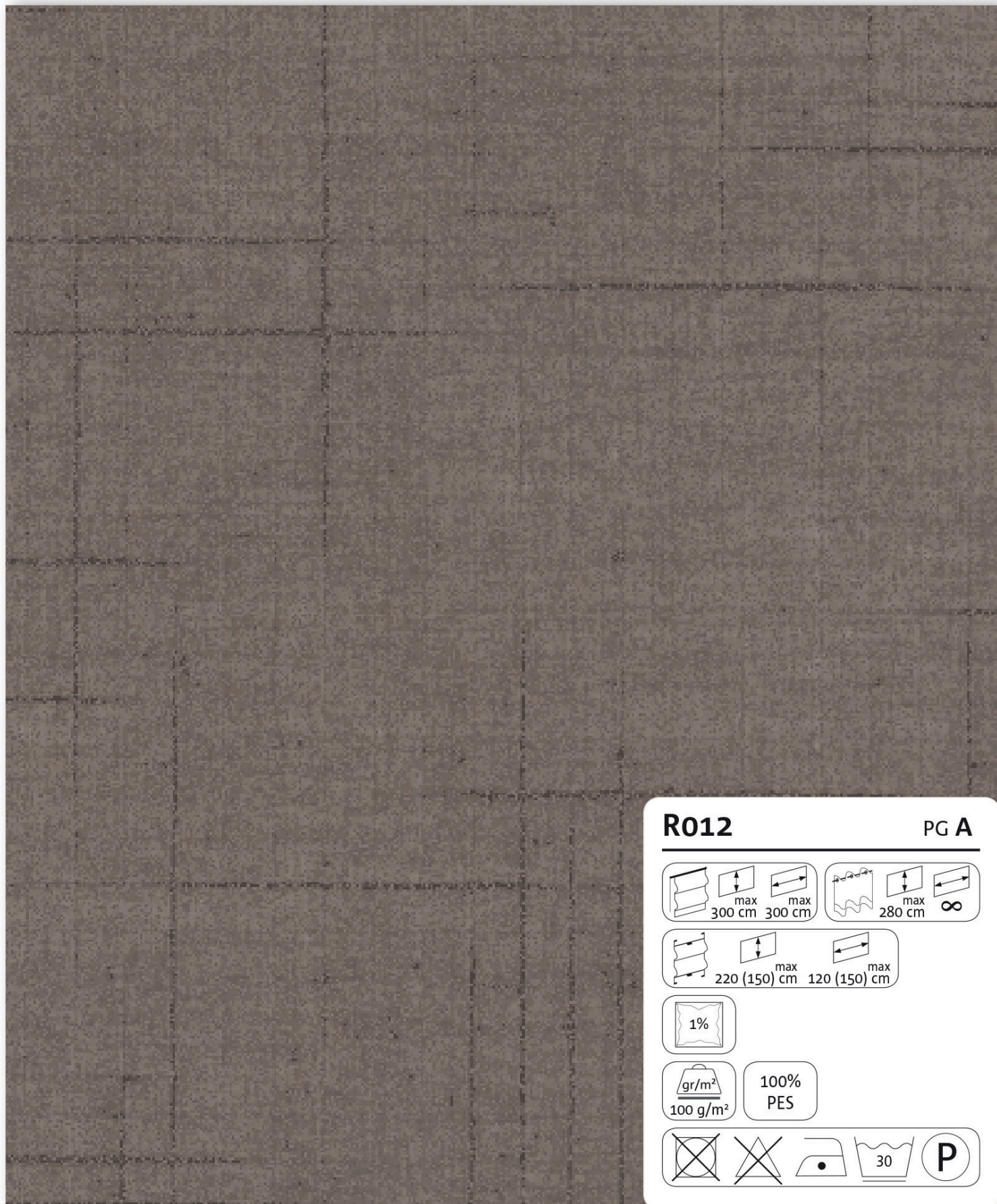

R012

PG A

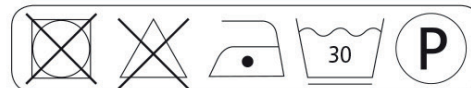
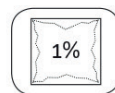
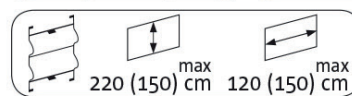
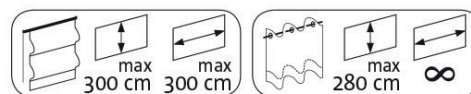

R012

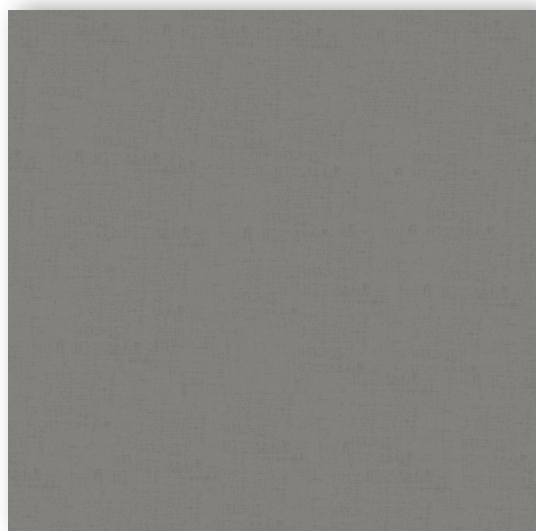

R023

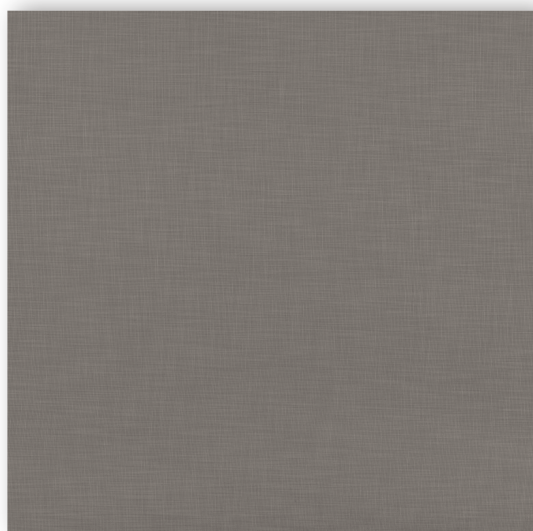

R816



R238

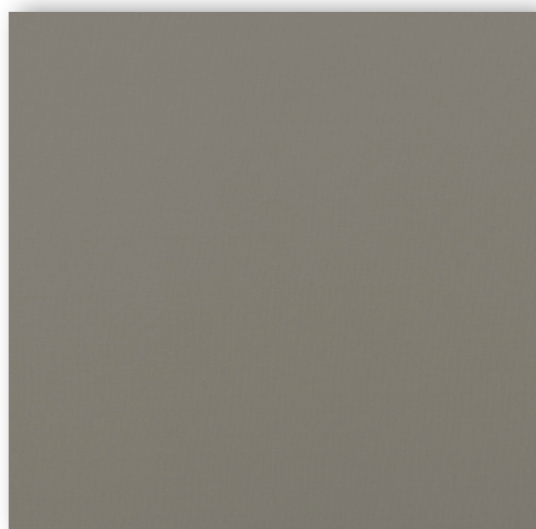

R416

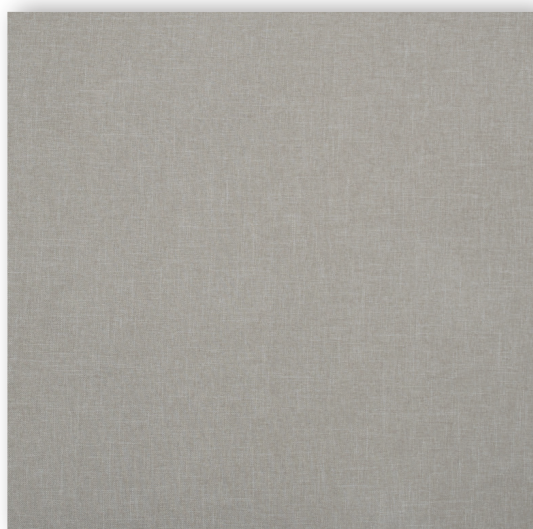

R636



R425



R240

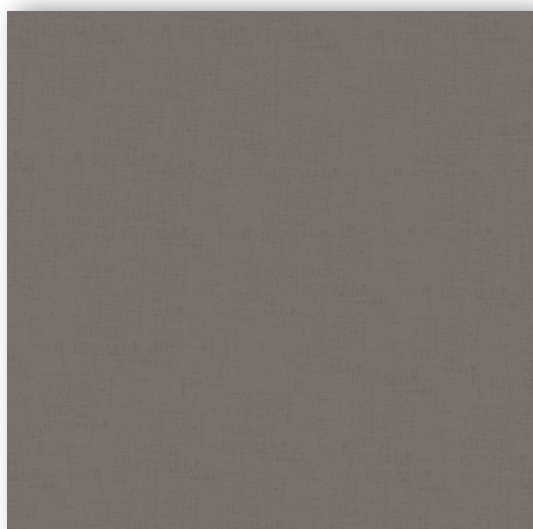

R024

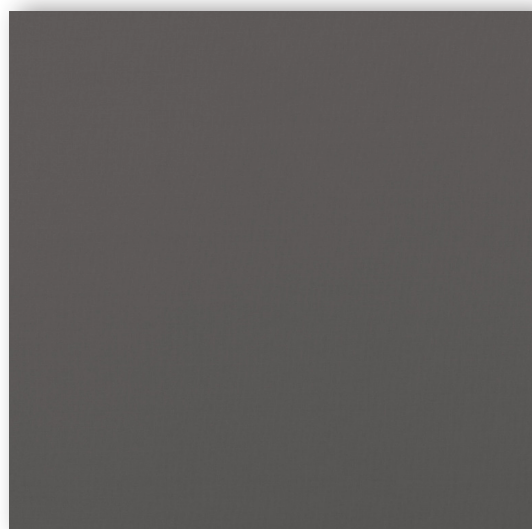

R415

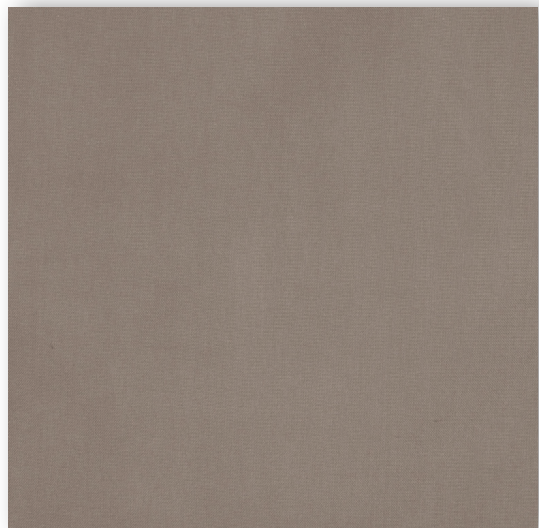

R846

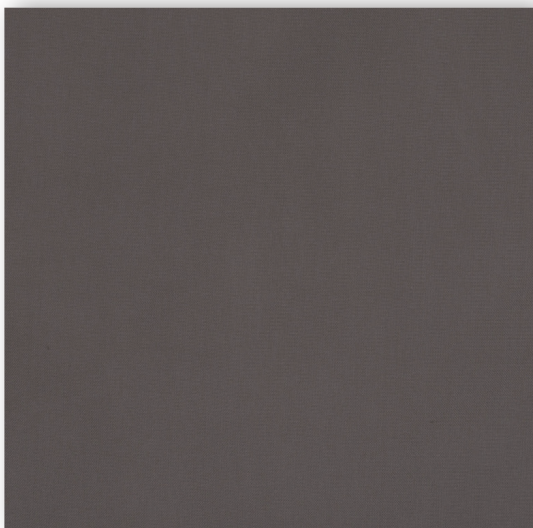

R847

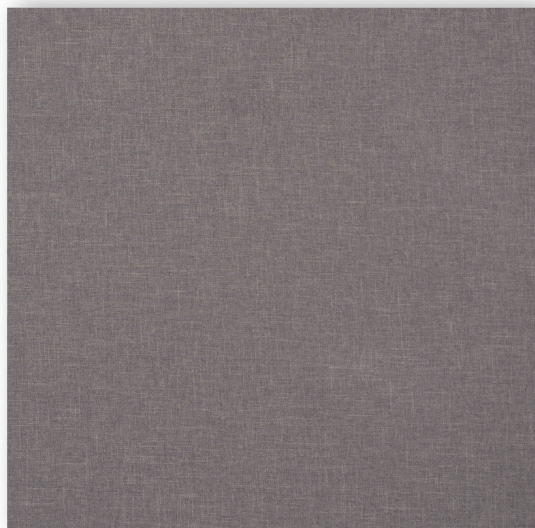

R635

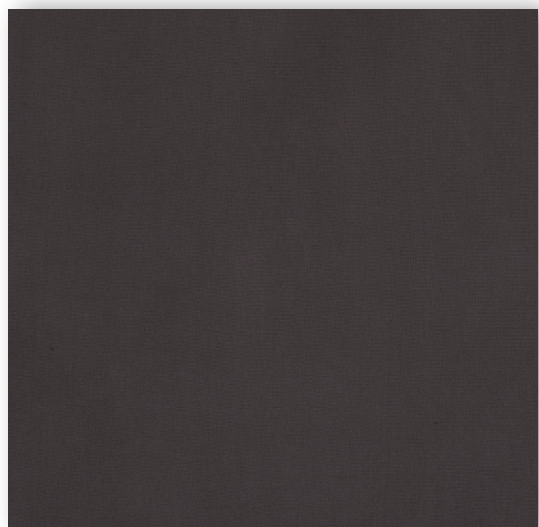

R845



R821

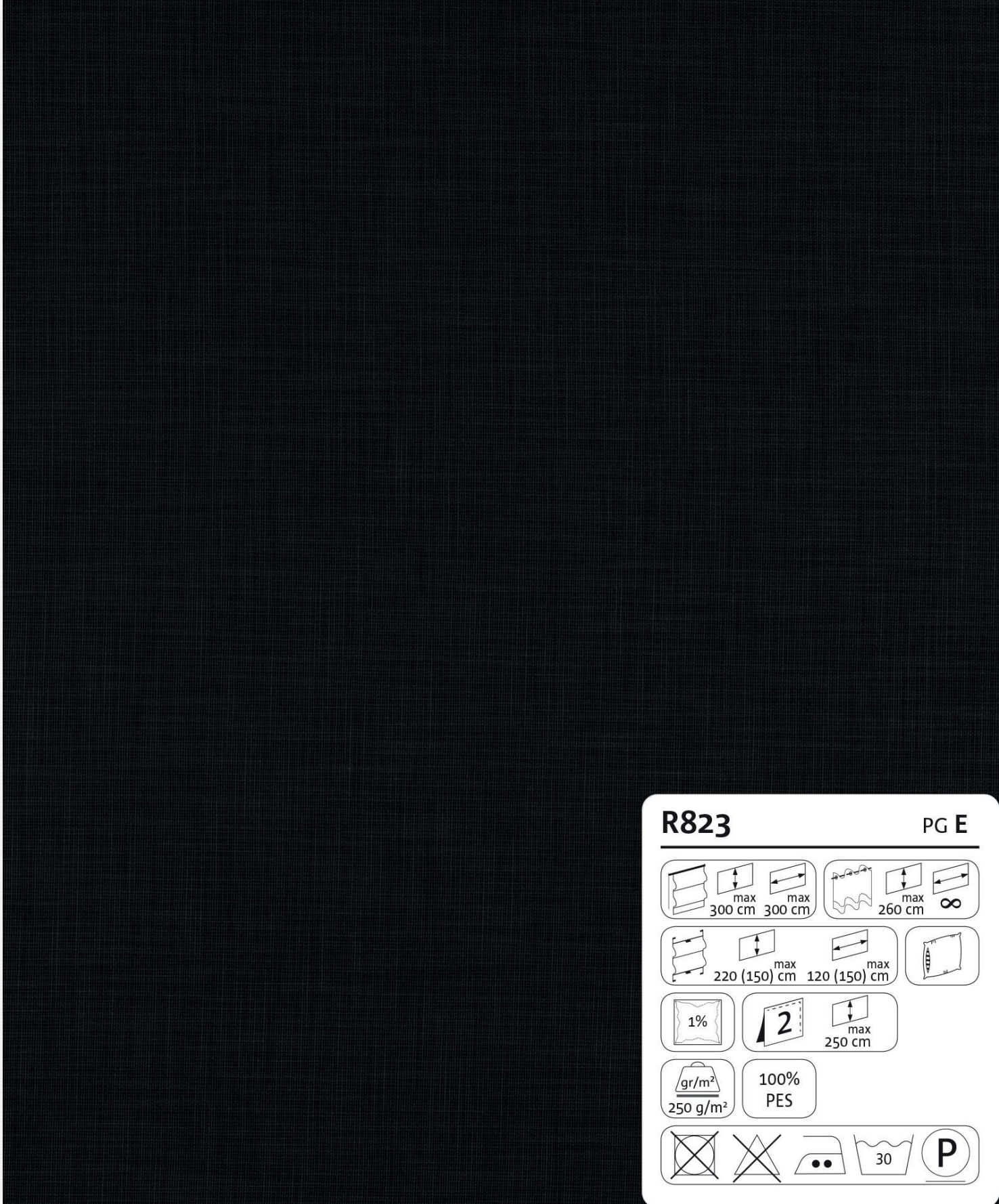

R823

PG E

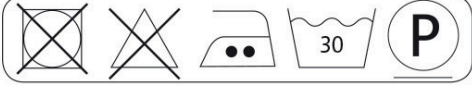
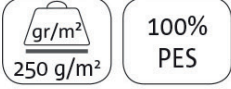
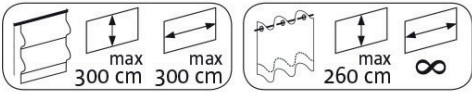

R823



R644



R213



R830



R428

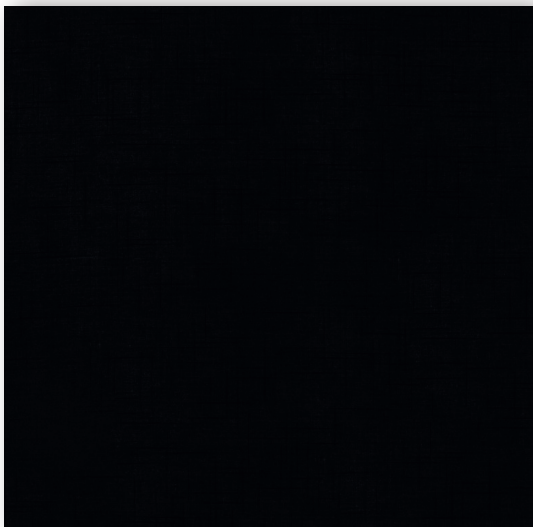

R013

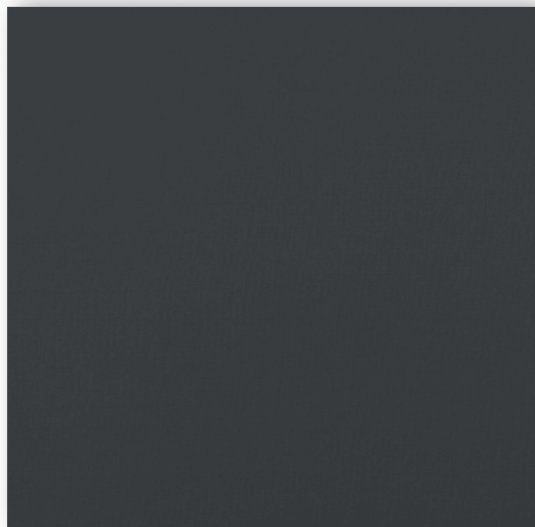

R419

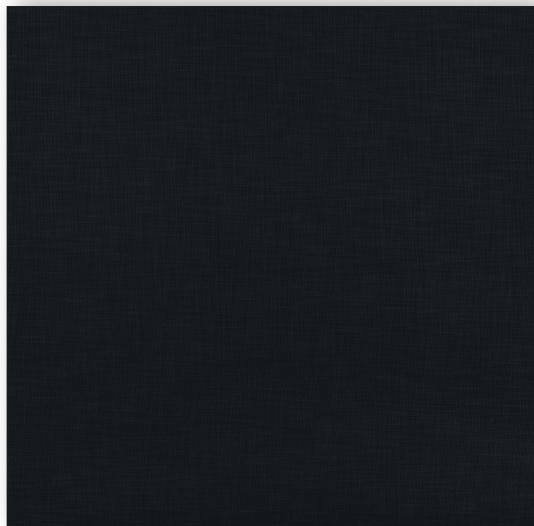

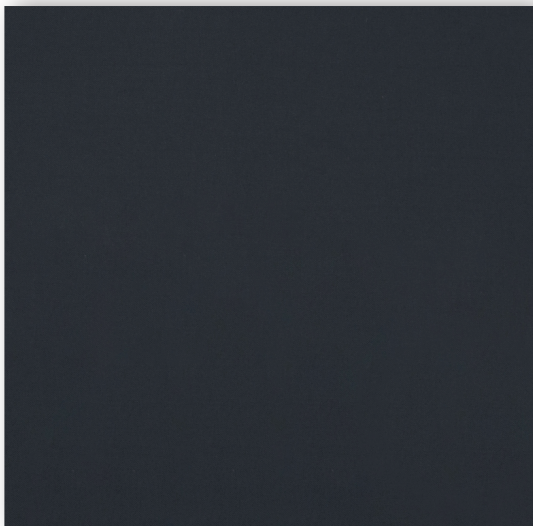

R824



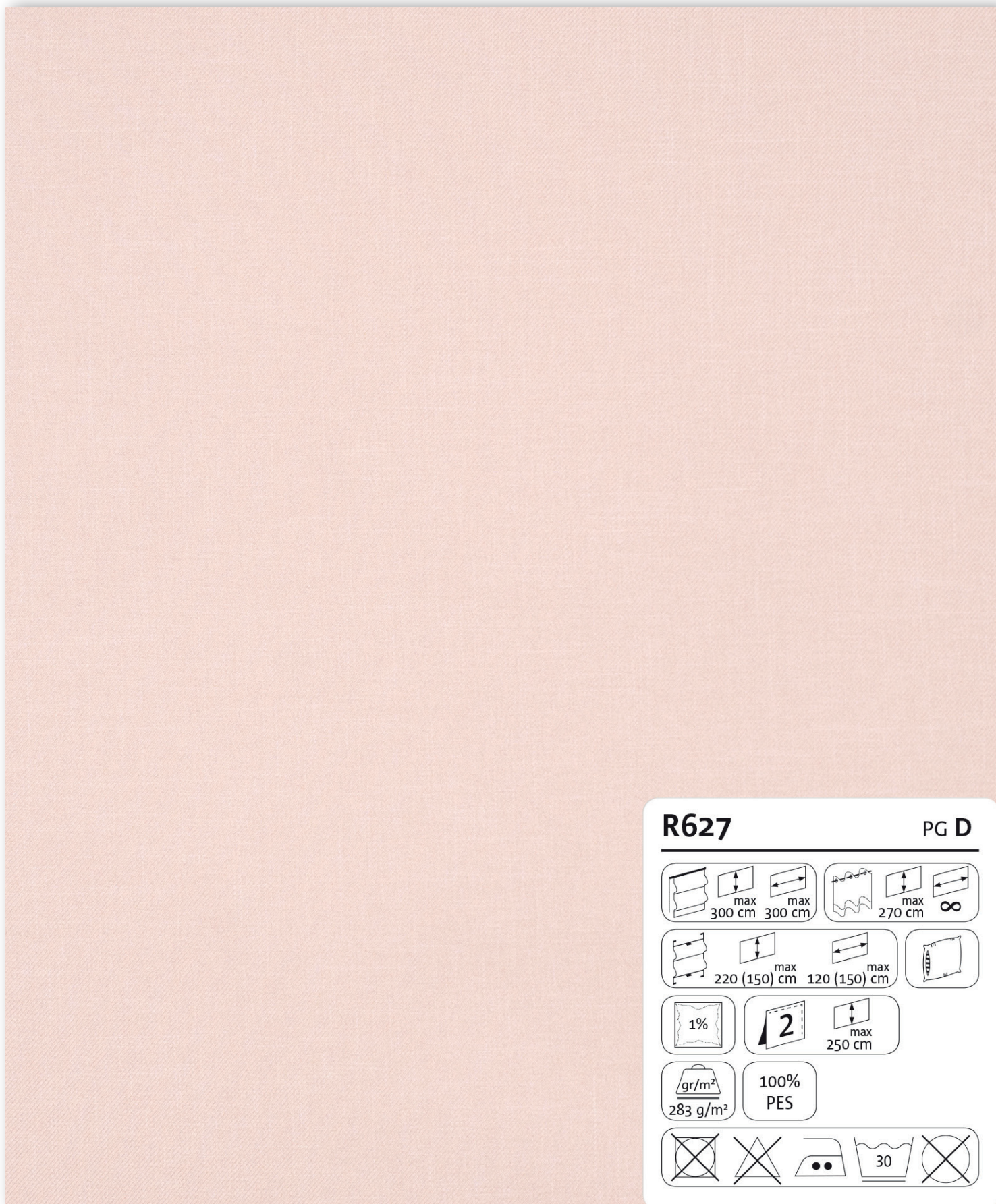





R643







R627 **PG D**





  
300 cm 300 cm

  
270 cm ∞

   
220 (150) cm 120 (150) cm

  
250 cm

 
283 g/m² PES

R627

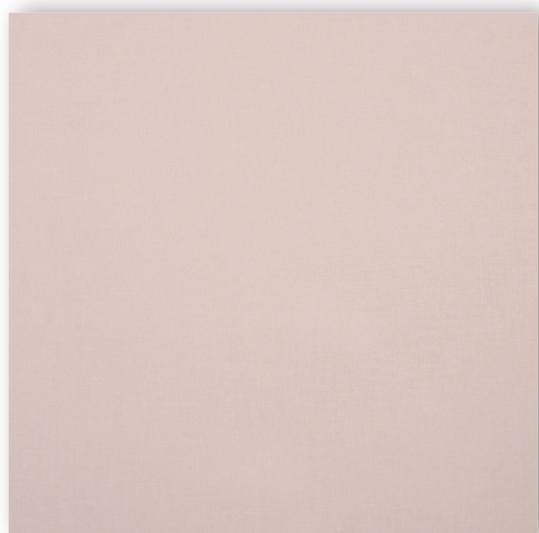

R626

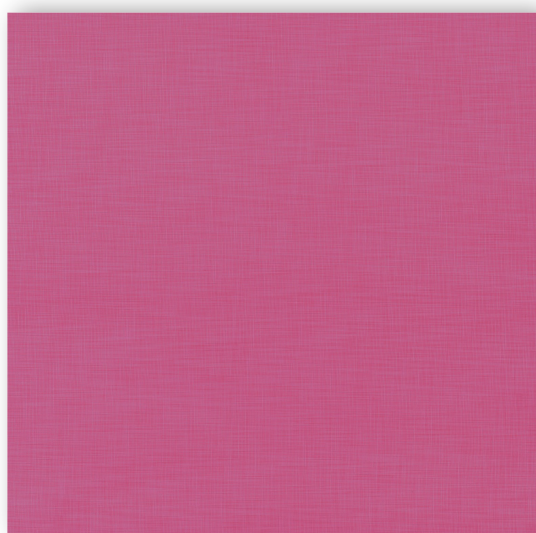

R811



R628

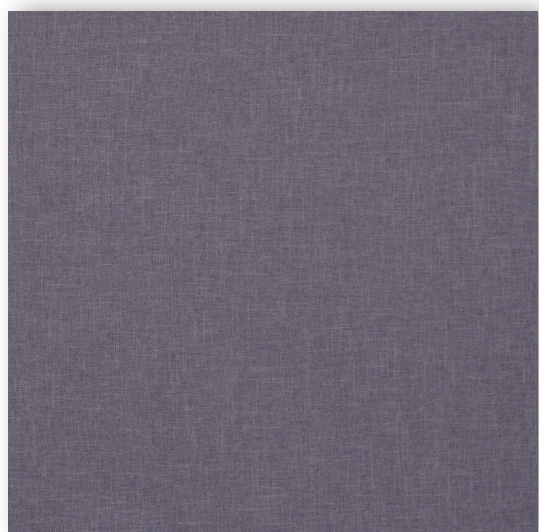

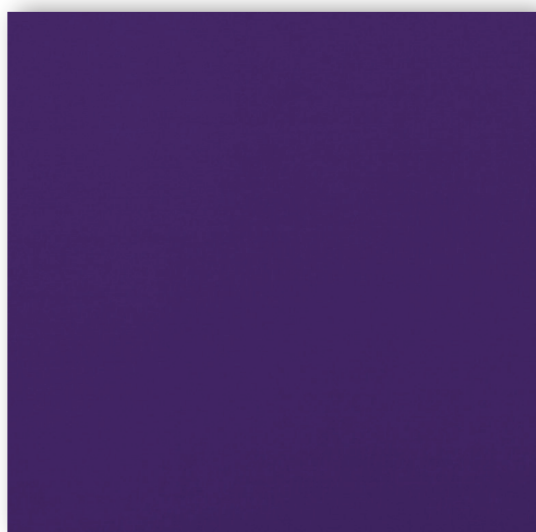

R634



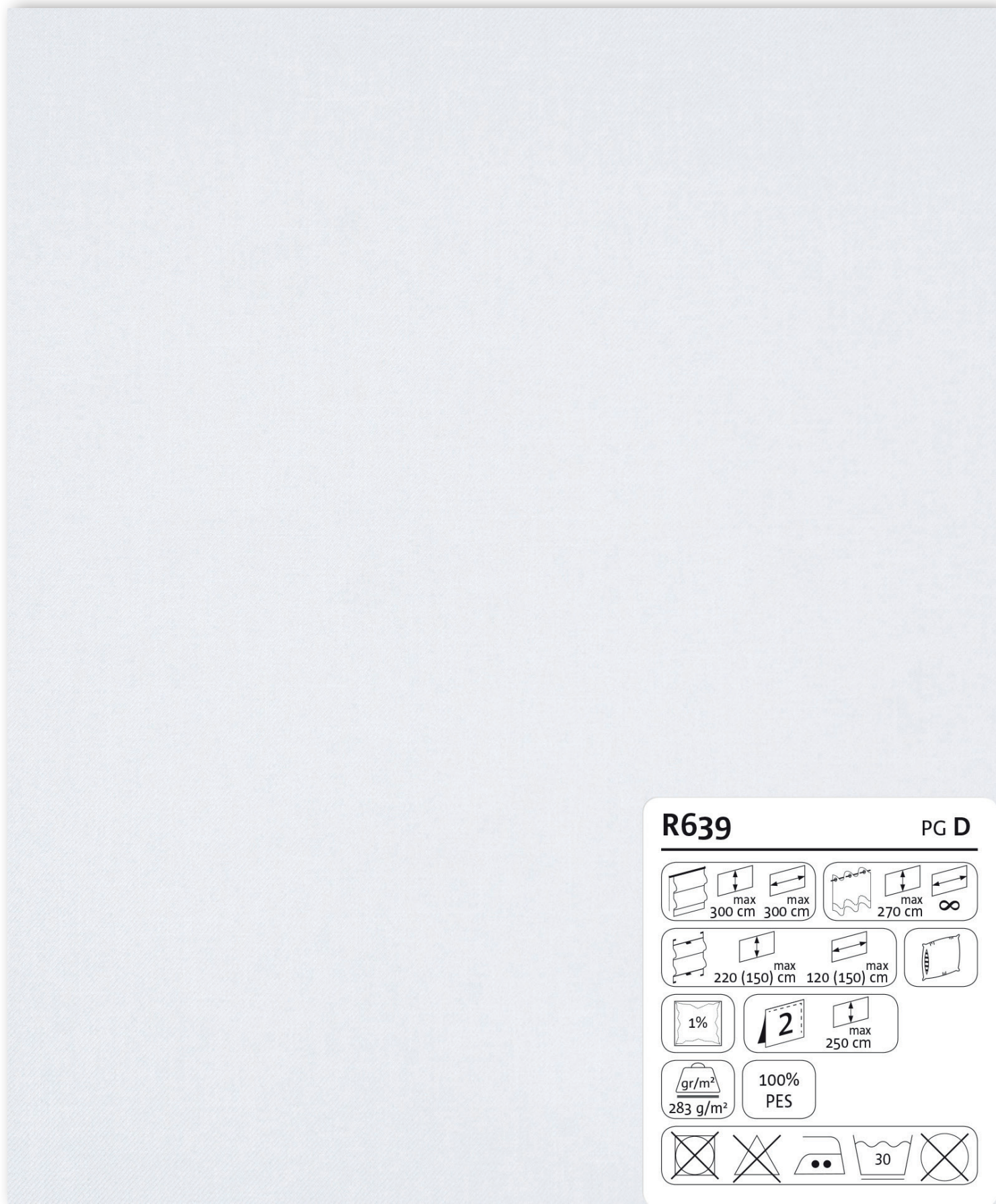

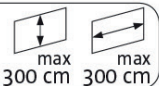

R413

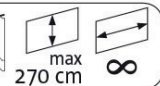

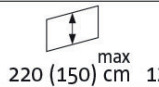





R639 **PG D**

 

R639

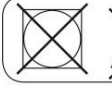

R008

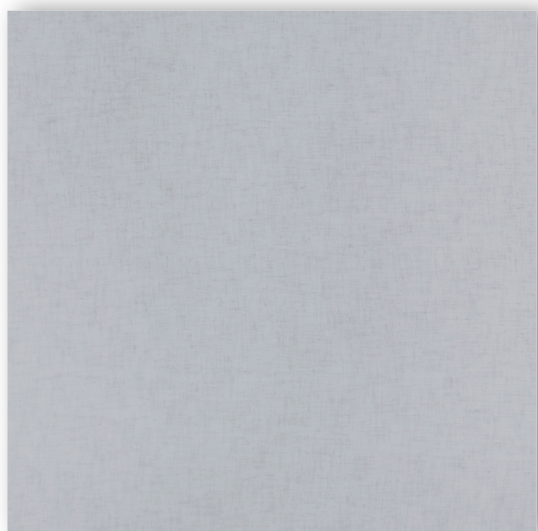

R019

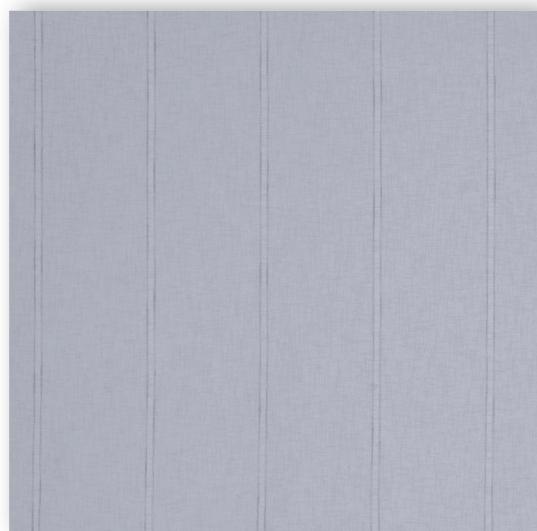

R005

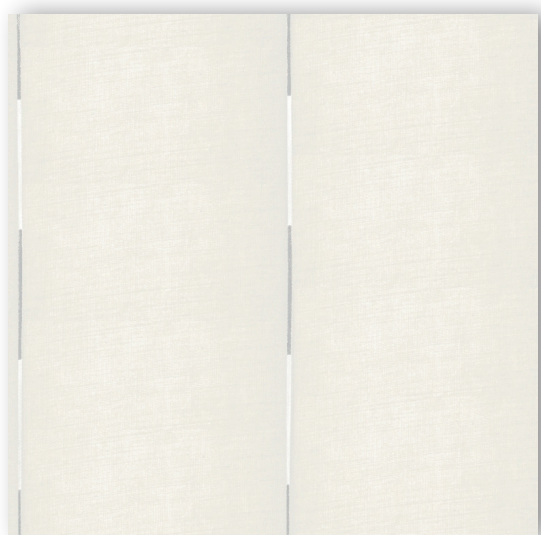

R242



R026



R426

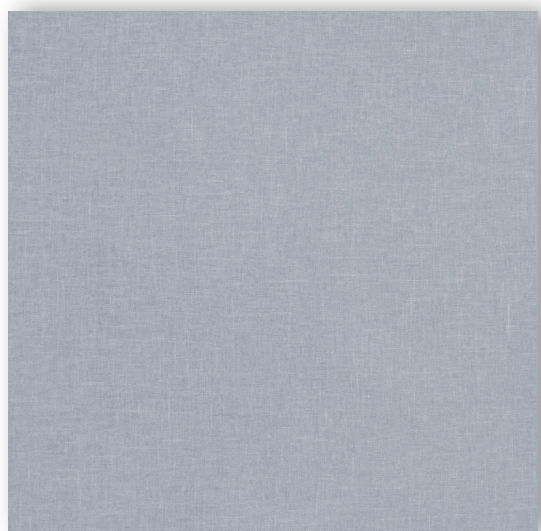

R638

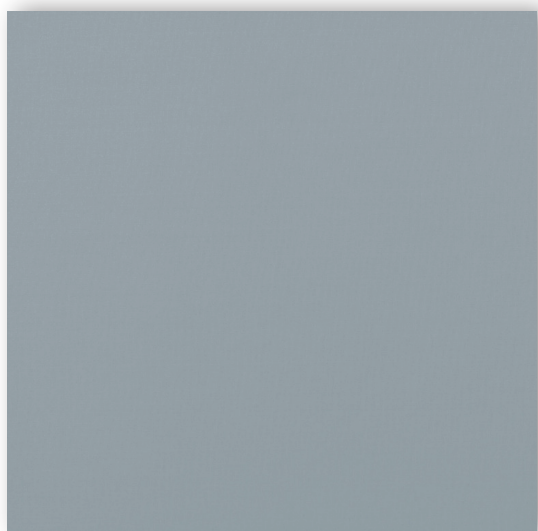

R418

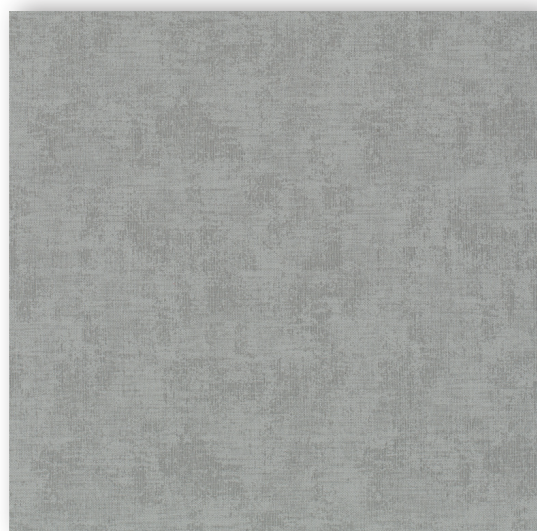

R829



R401

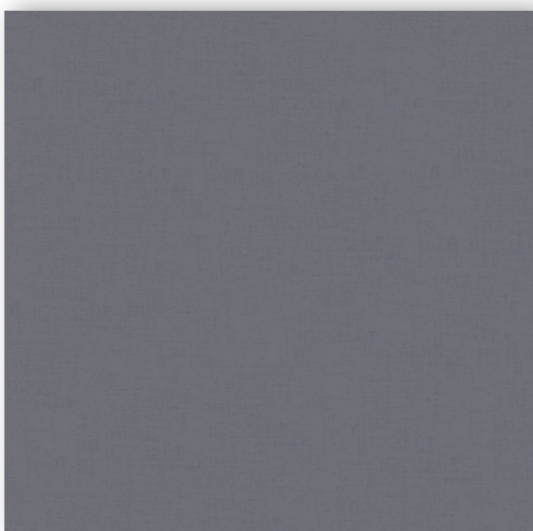

R025



R018



R850



R602



R828



R642

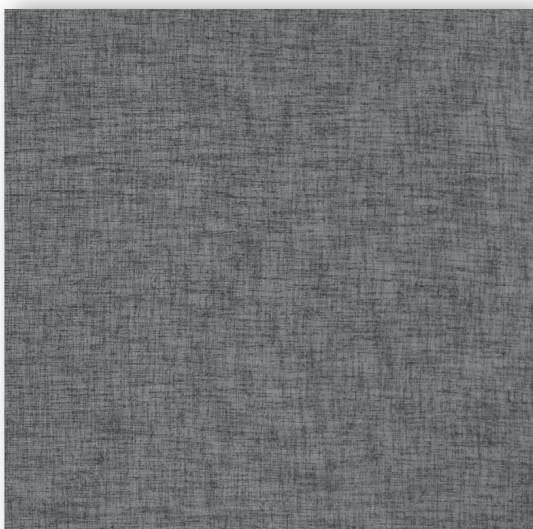

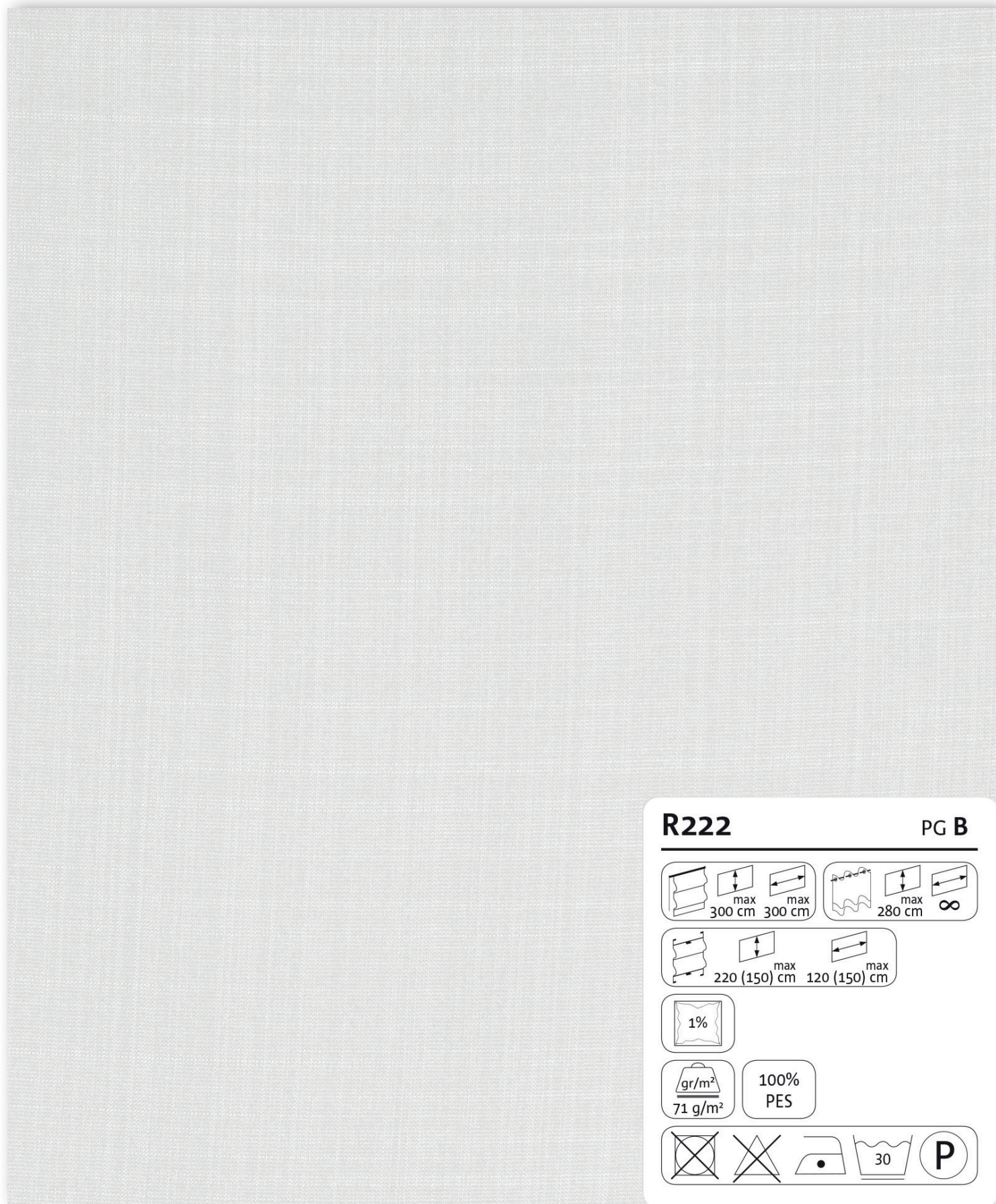

R212



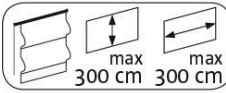
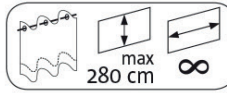

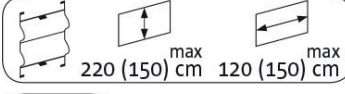



R222 **PG B**

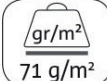



R222

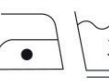

R804

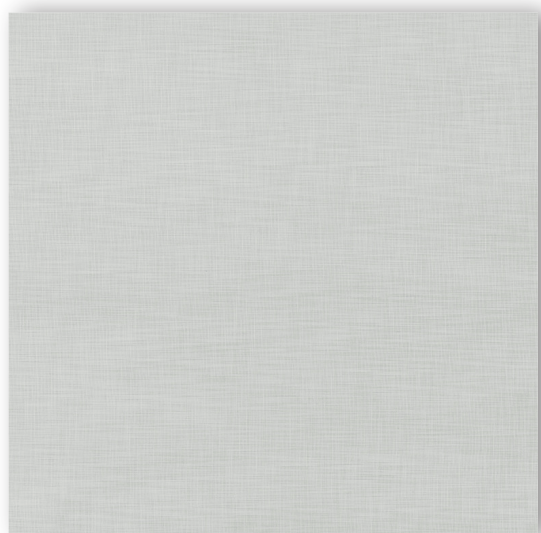

R211

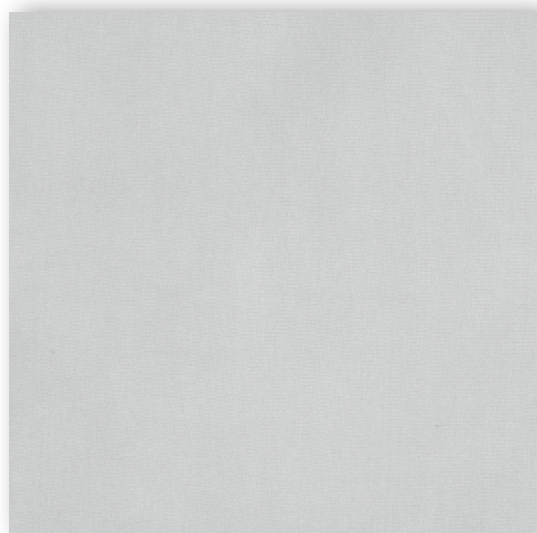

R836



R417

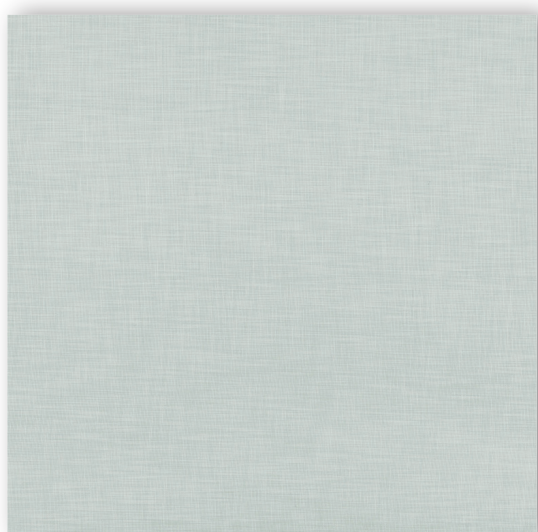

R820

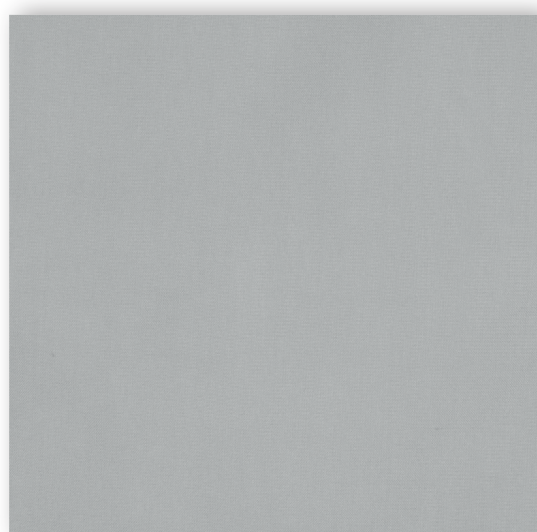

R849



R236

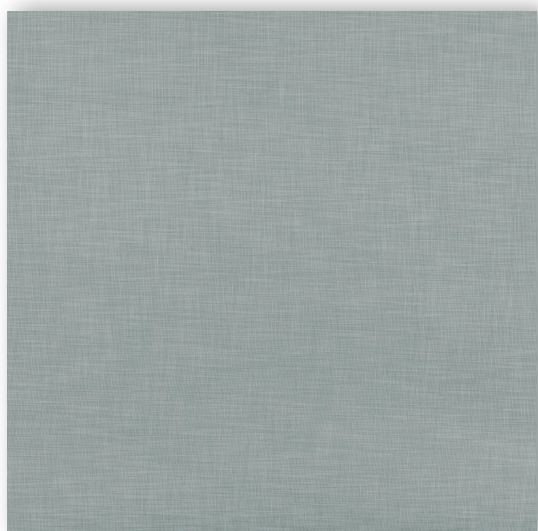

R818

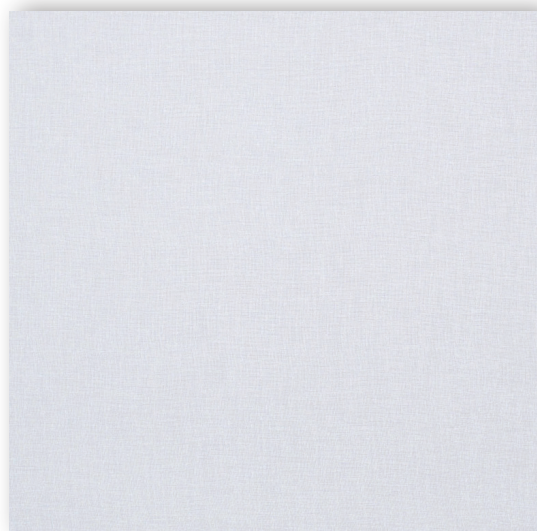

R206

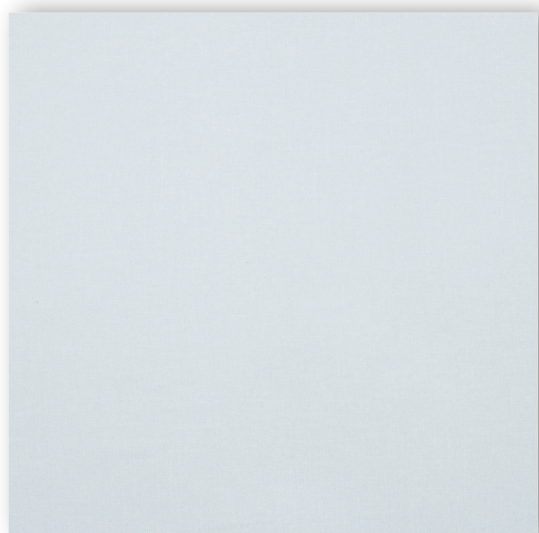

R629

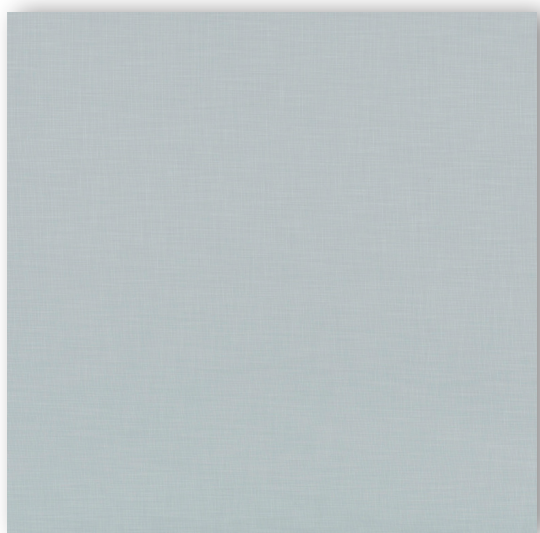

R813

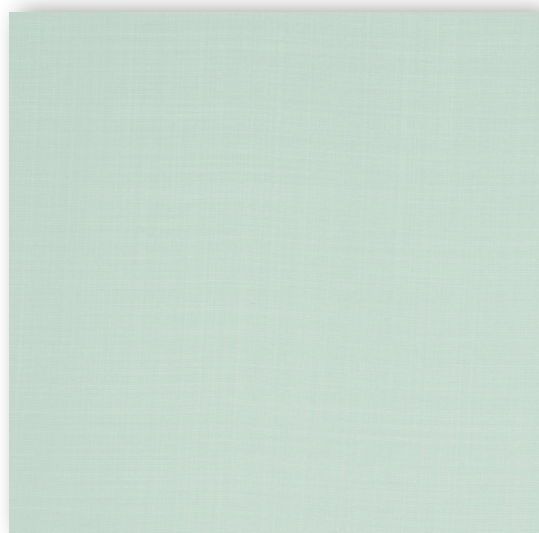

R221

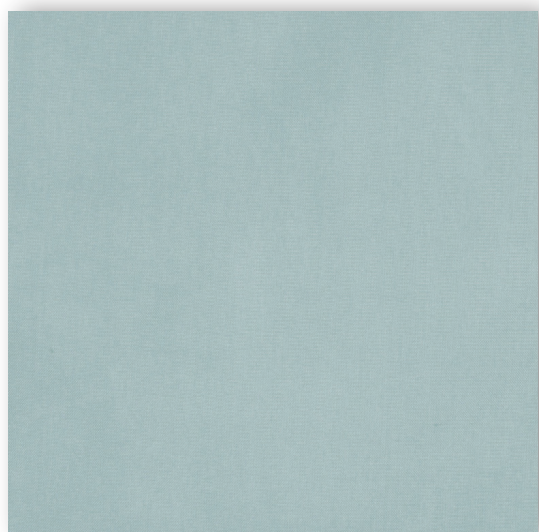

R843

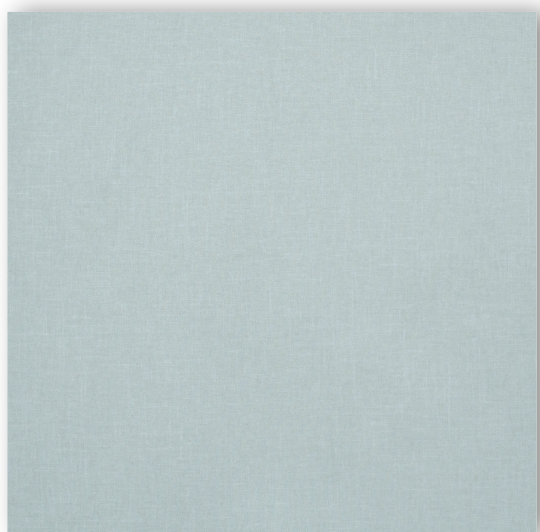

R620

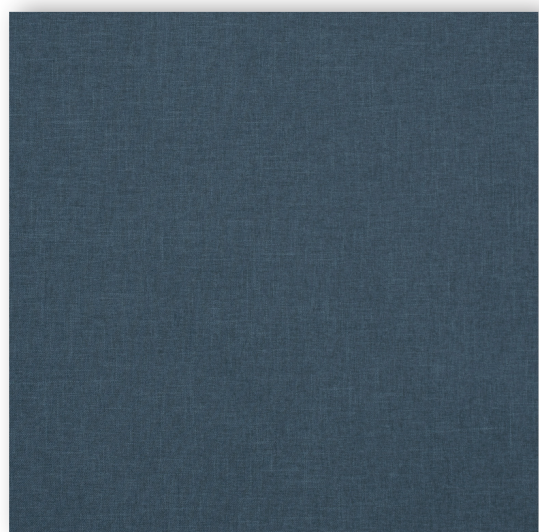

R622



Blackout

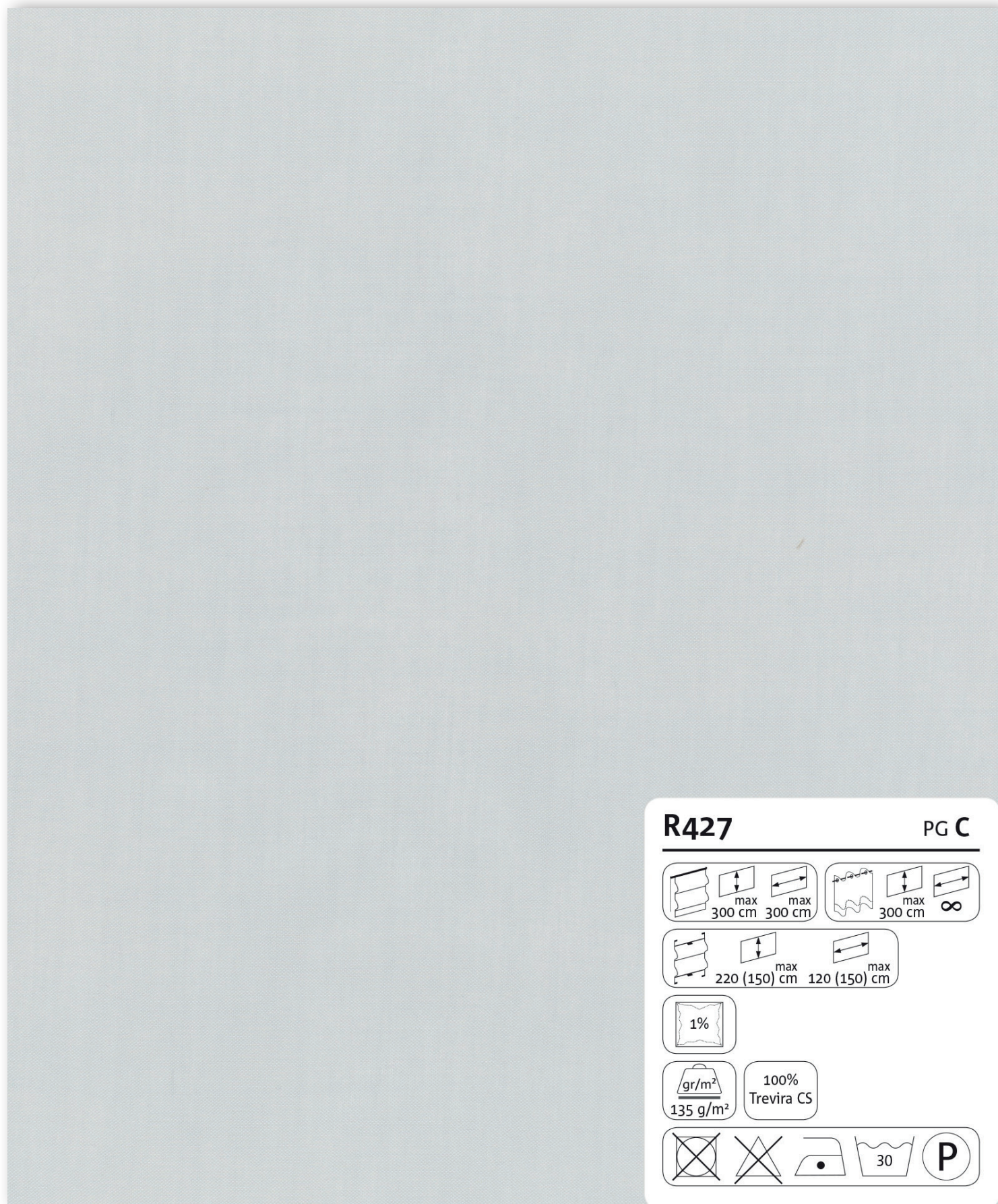

R427

PG C

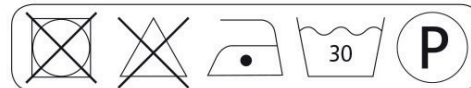
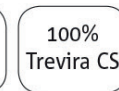
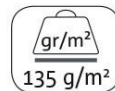
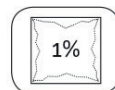
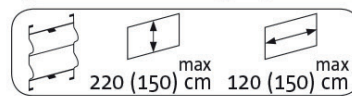
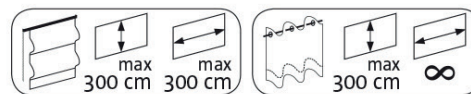

R427

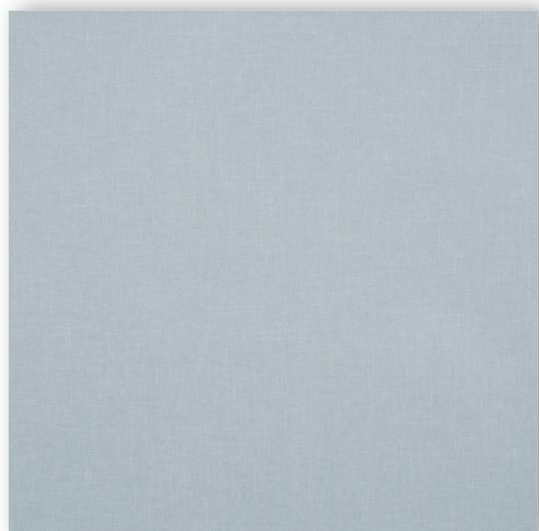

R630

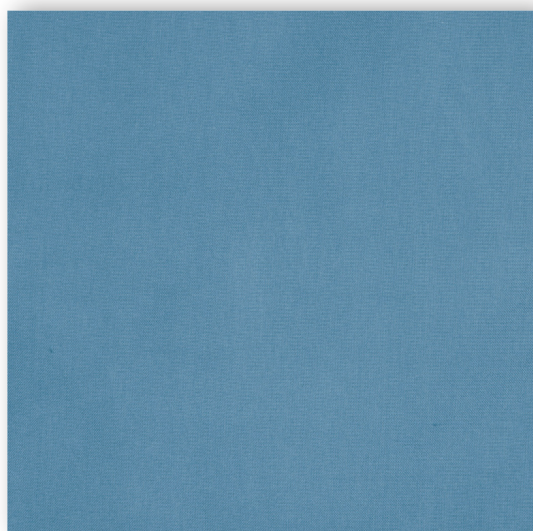

R844



R633



R842



R812



R632

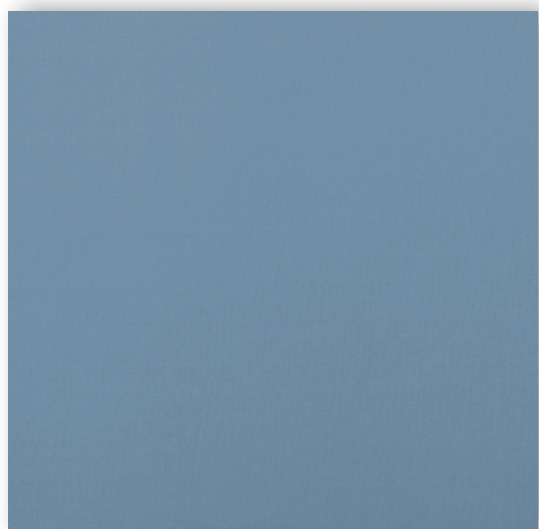

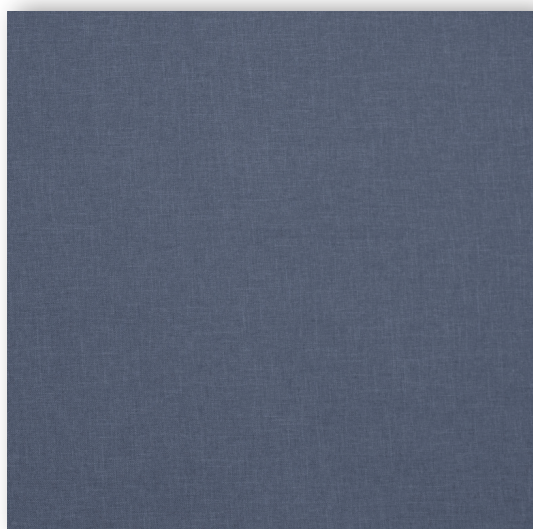

R412



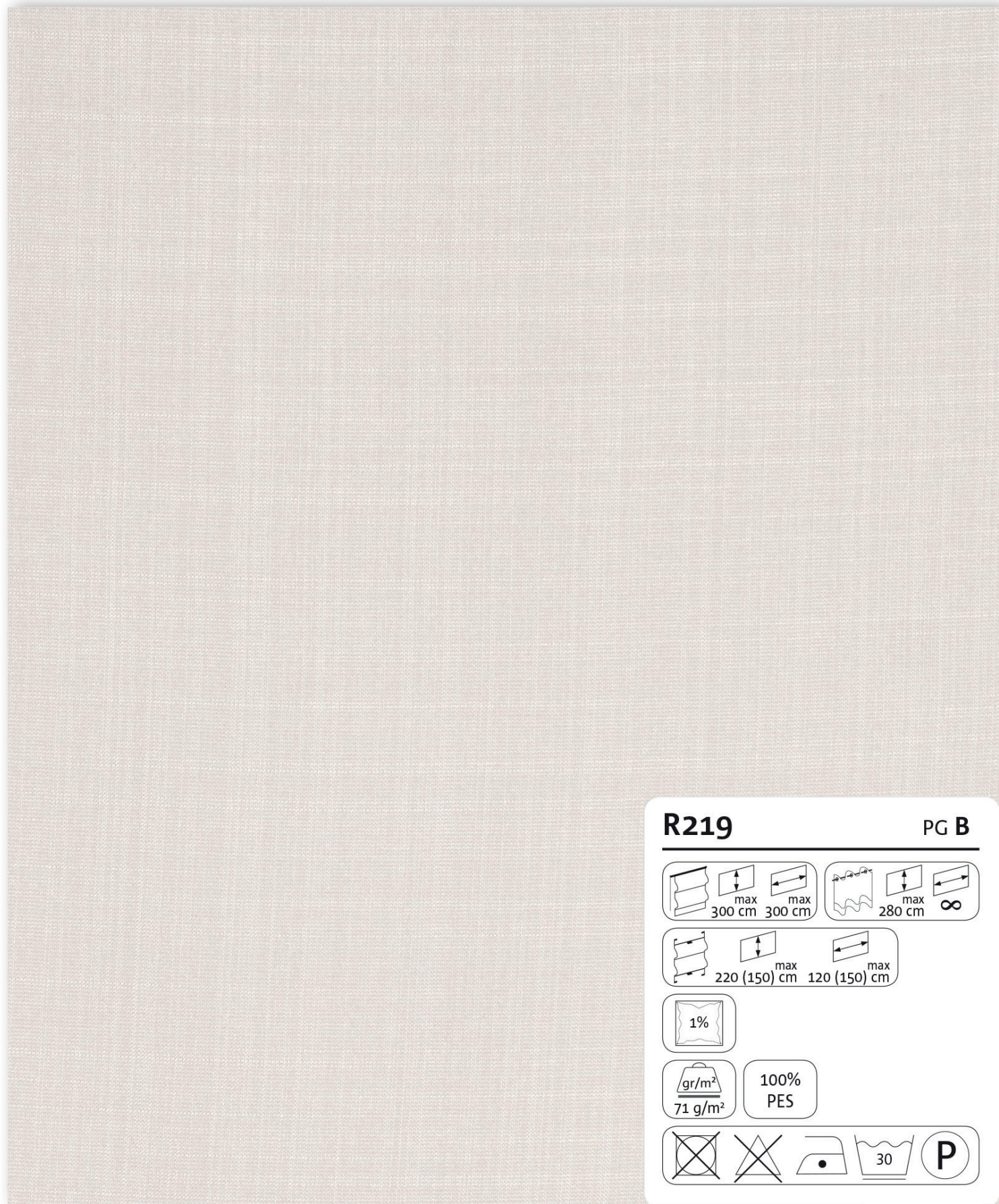





R631





R219 **PG B**

  
300 cm 300 cm





   
280 cm

  
220 (150) cm 120 (150) cm

 1%

 71 g/m²

 100% PES

R219

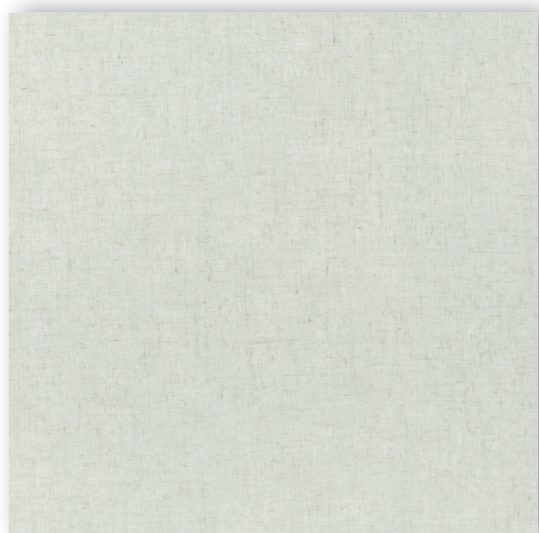

R232

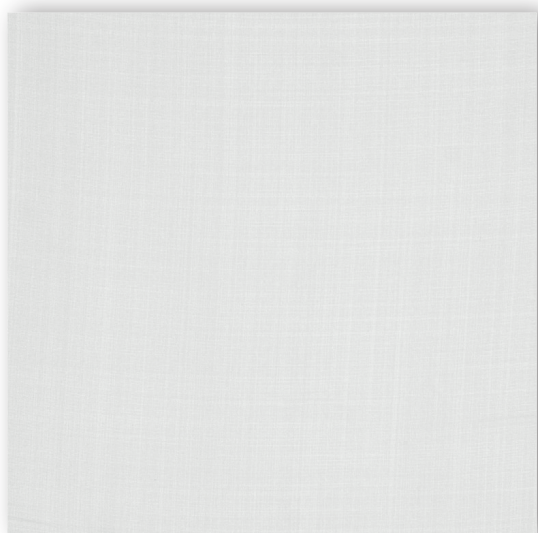

R222



R802

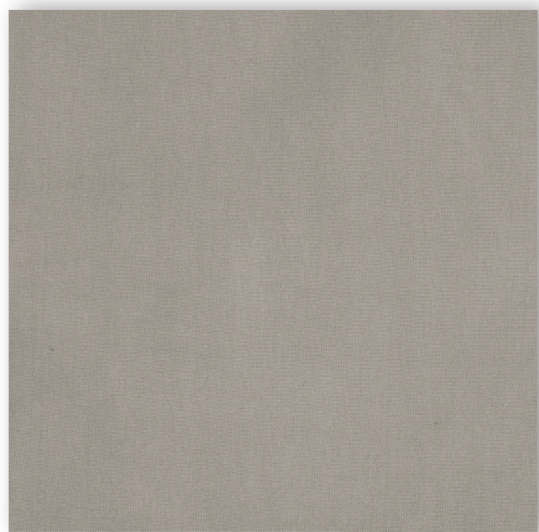

R835

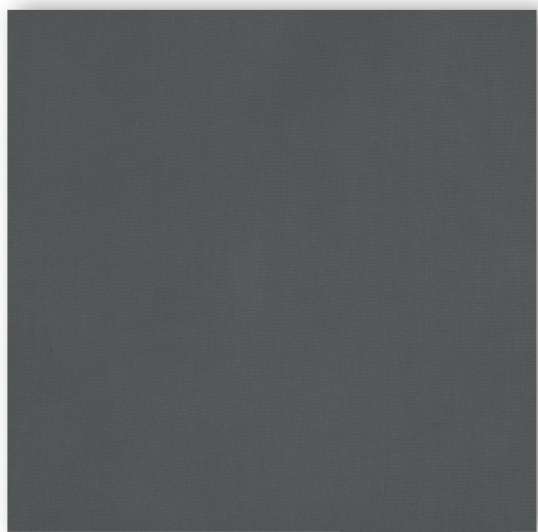

R848

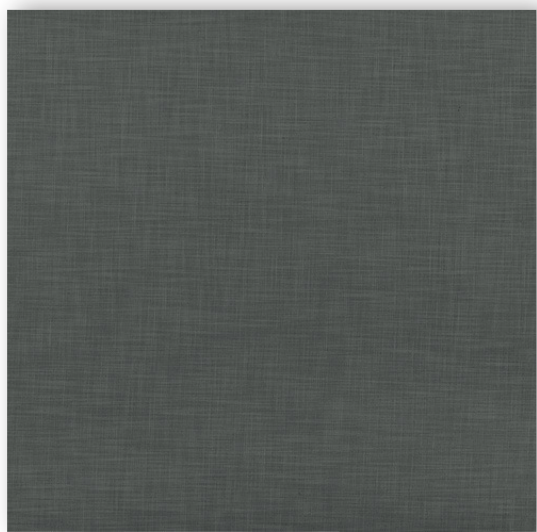

R819

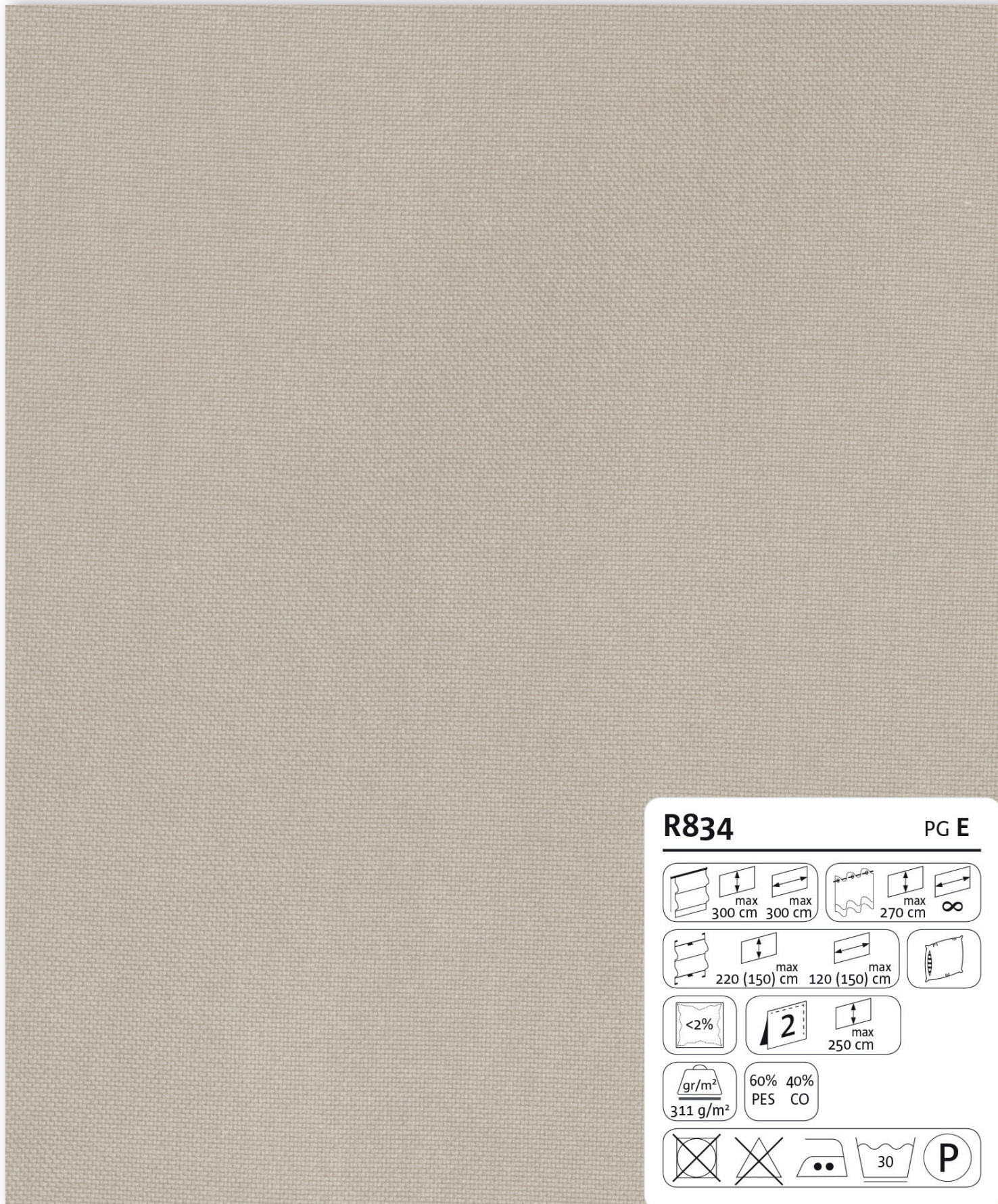

R834

PG E

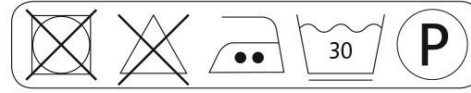
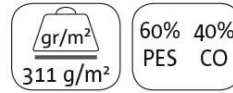
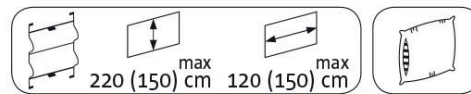
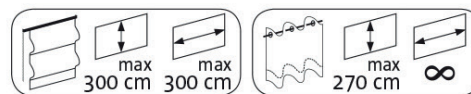

R834

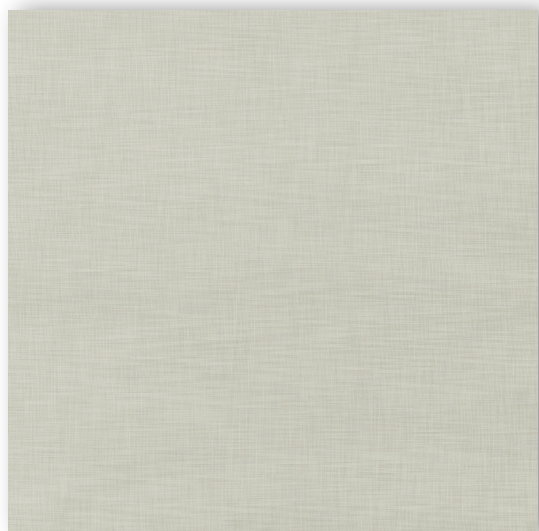

R803

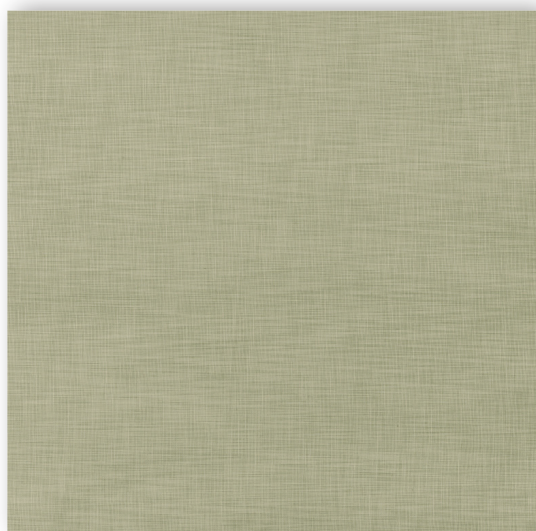

R806

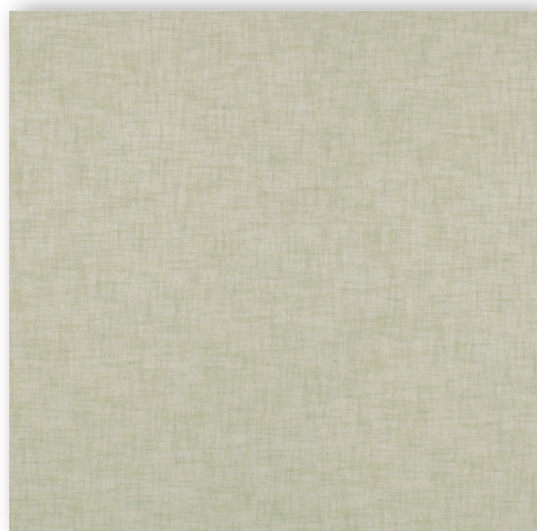

R205

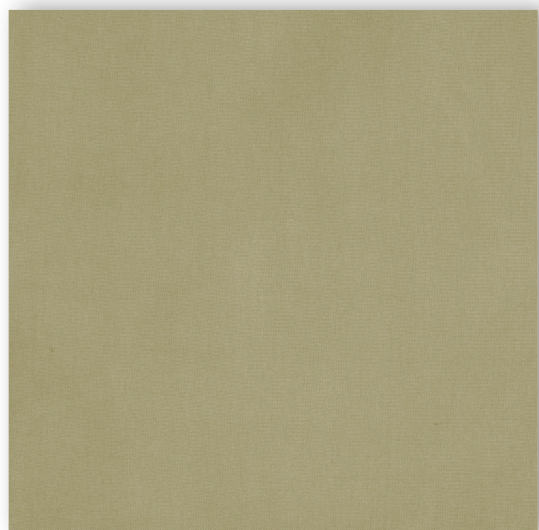

R839

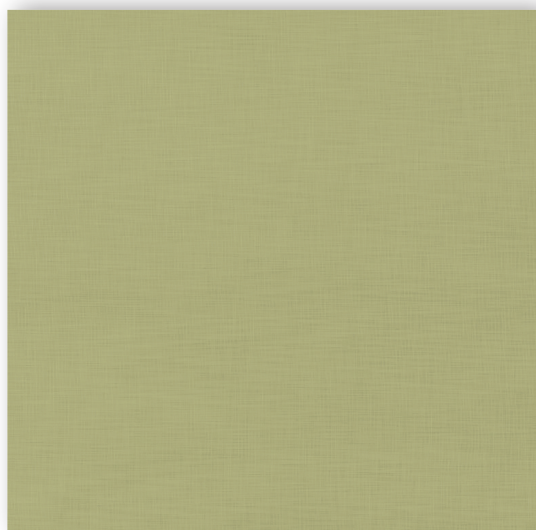

R808



R621

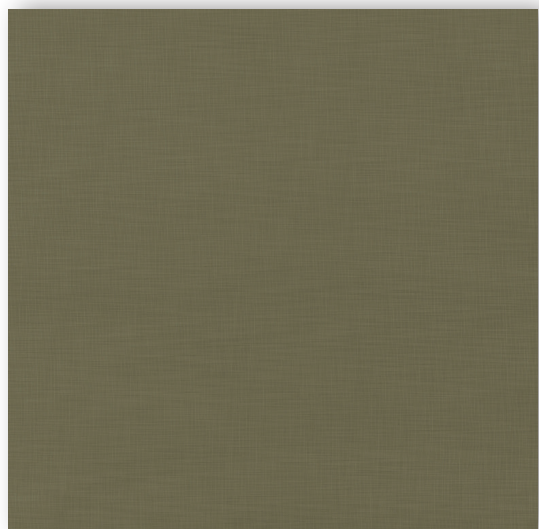

R810



R805



R807



R411

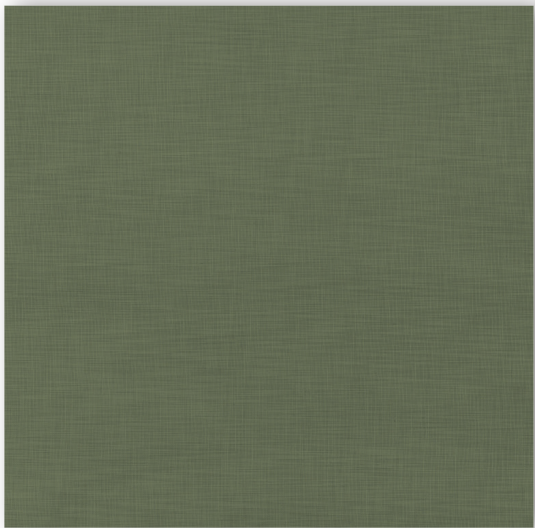

R809

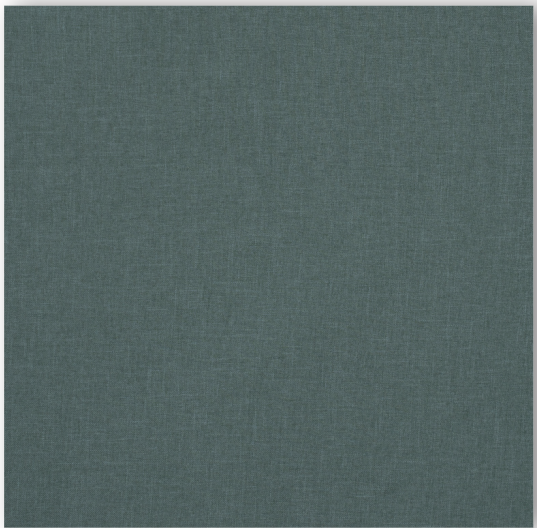

R623



Blackout

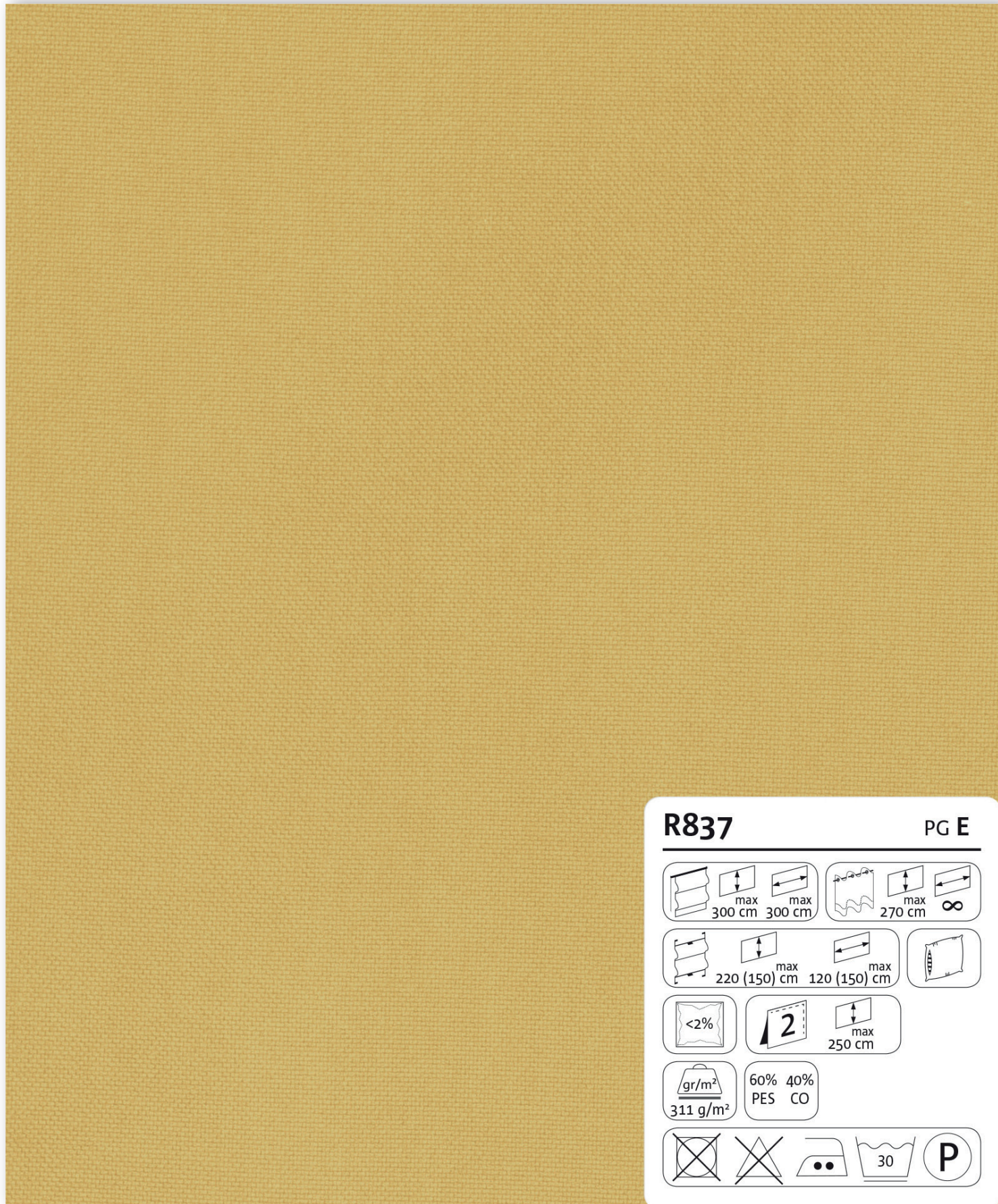

R837

PG E

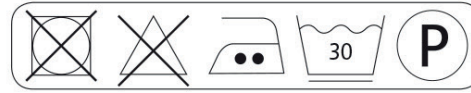
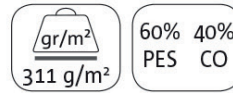
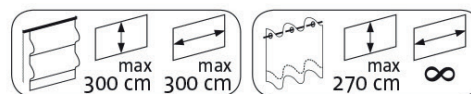

R837

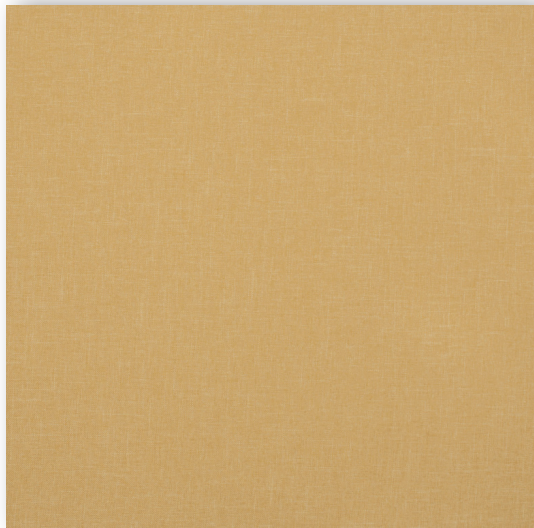

R618

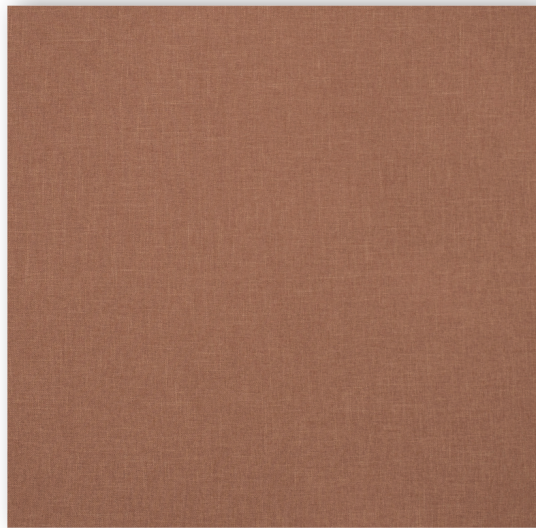

R619

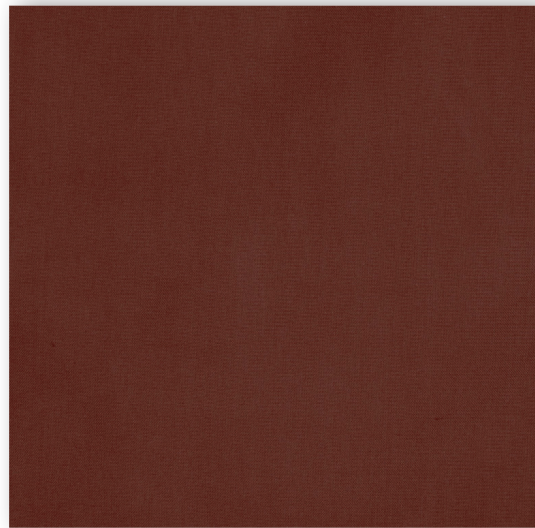

R841

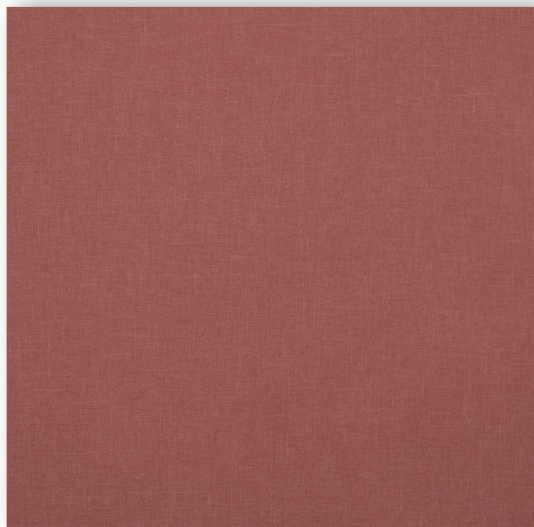

R624

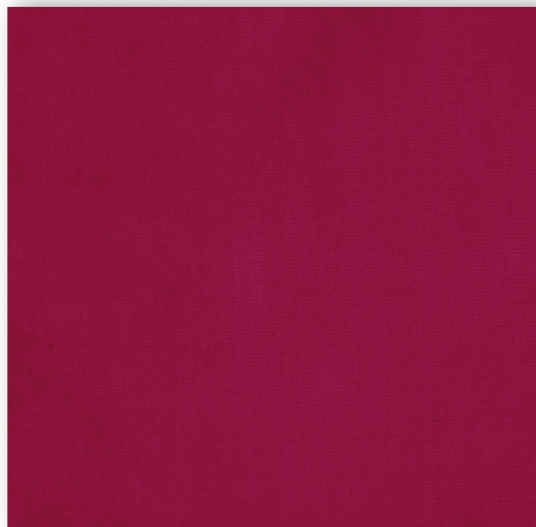

R840

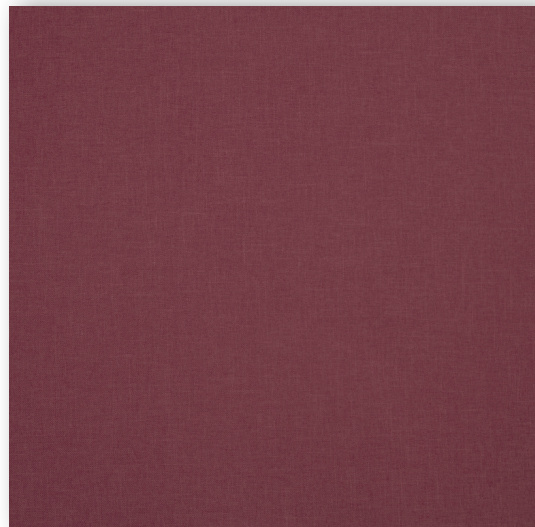

R625

R603

PG D

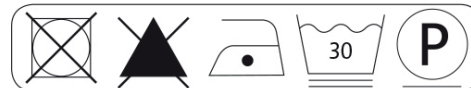
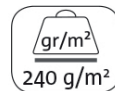
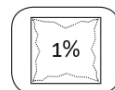
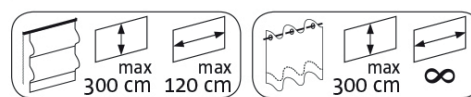

R603

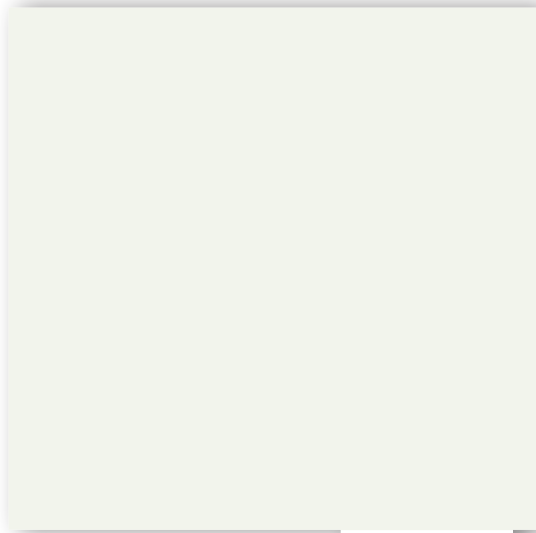

R604

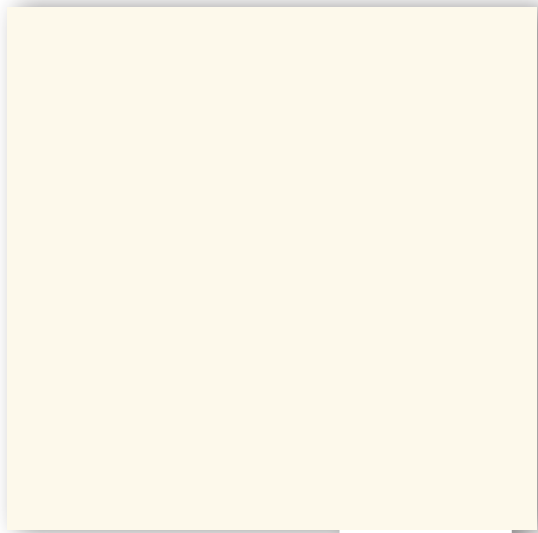

R605

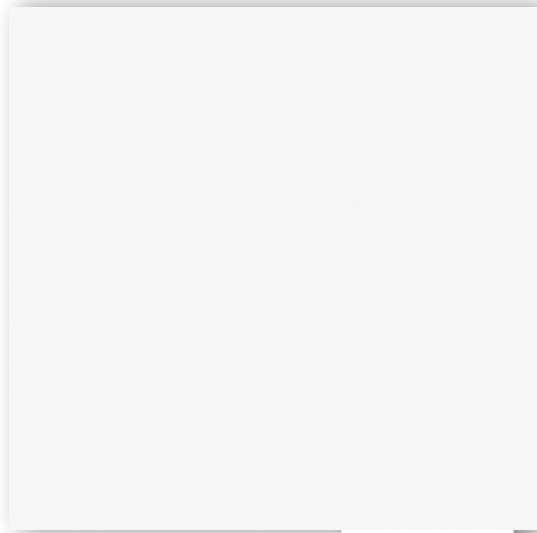

R223

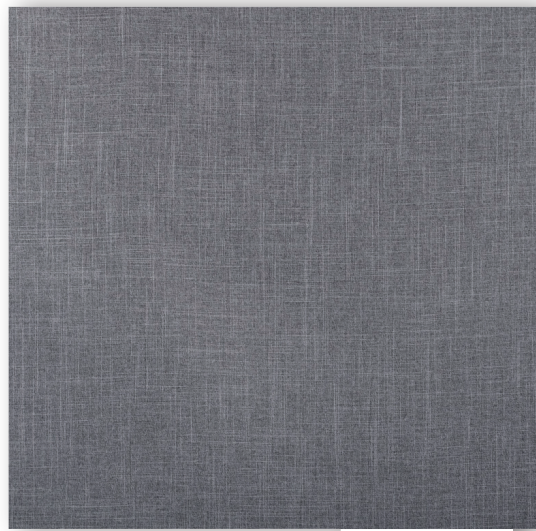

R408

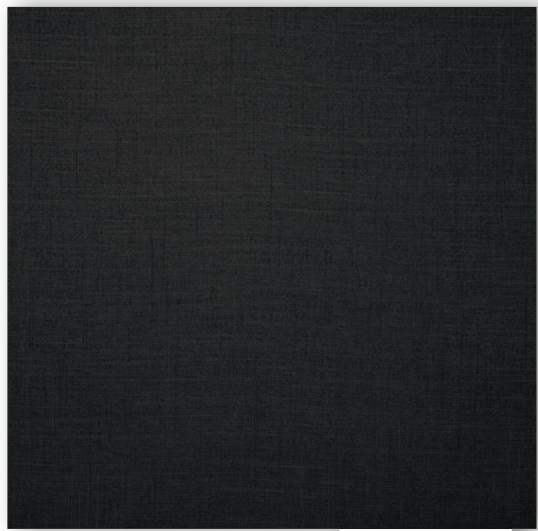

R409



R228

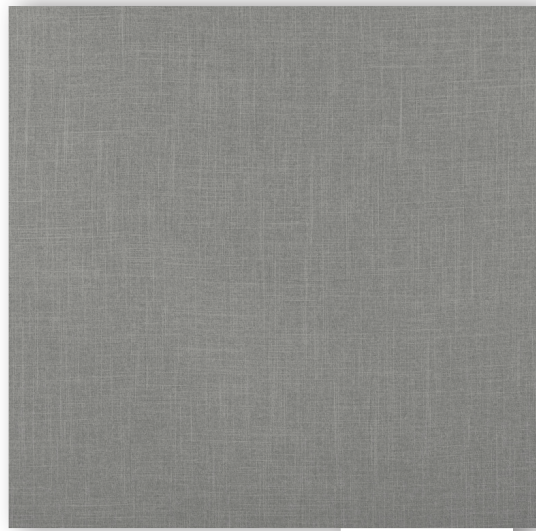

R407



R609



R606

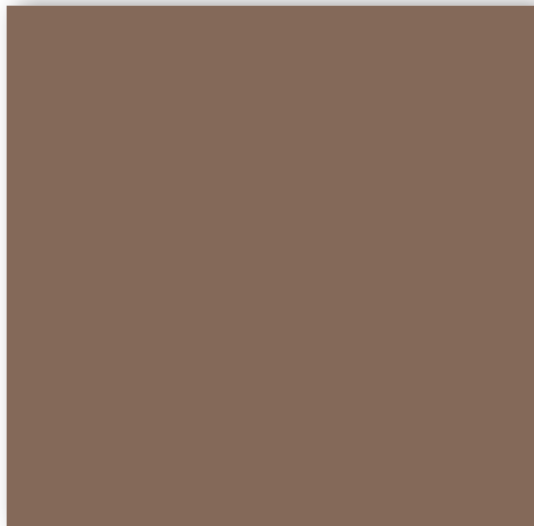

R607



R608



R610



R611

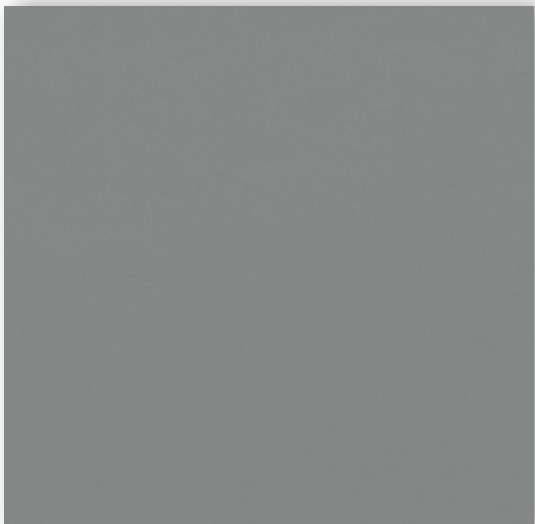

R227

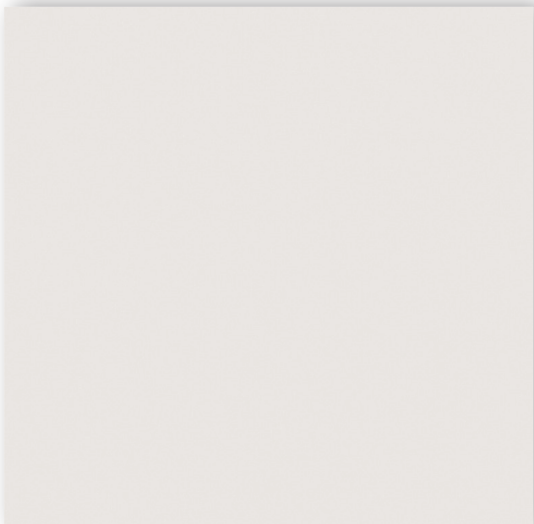

R224

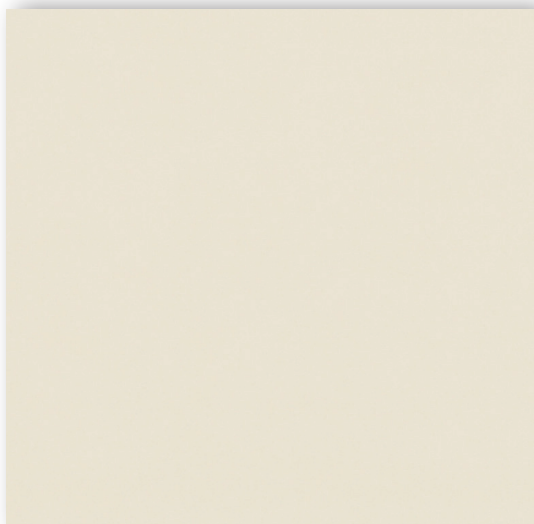

R225



R404



R403



Blackout



R226



R405



R406



R402



R229

symbol
tkaniny

R001

grupa
cenowa

PG 1



Zastona rzymska
max wysokość wyrobu
max szerokość wyrobu



Zastona Flex
Zastona Rings
max wysokość wyrobu
max szerokość wyrobu

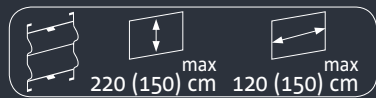

Zastona rzymska R VS
max wysokość wyrobu
max szerokość wyrobu



Poduszka 50x50 cm



opcja podszewki zaciemniającej,
kolor podszewki
(nieдоступna dla Zastony rzymskiej R VS)
max wysokość wyrobu z podszewką

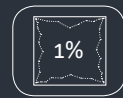

kurczliwość materiału



gramatura materiału



skład materiału
PES - poliester, CO - bawełna, LI - len,
Trevira CS - poliester trudnopalny

Konserwacja:



nie suszyć w suszarce bębnowej



nie wybielać
przy miejscowym usuwaniu plam zachować szczególną ostrożność,
a środek wcześniej wypróbować na próbce tkaniny



nie stosować wybielaczy



maksymalna temperatura prasowania 110°C



maksymalna temperatura prasowania 150°C



maksymalna temperatura prasowania 200°C



prasowanie w temperaturze 110°C bez użycia pary



maksymalna temperatura prania 30°C



maksymalna temperatura prania 30°C, proces łagodny



maksymalna temperatura prania 30°C, proces delikatny



czyszczenie na sucho z użyciem
powszechnie używanych środków



czyszczenie na sucho z użyciem
powszechnie używanych środków, proces łagodny



nie czyścić na sucho